



**QUARRY MULTI-FAMILY  
PLANNED DEVELOPMENT NO. 66  
BASE ZONING DISTRICT: MF-1 MULTI-FAMILY  
ORDINANCE NO. 23-05-18-19  
(ADOPTED 5-18-2023)**

**AMENDED BY:**

- **MINOR PD AMENDMENT No. PDA24-0009:  
PROVIDING FOR THE INTERPRETATION OF  
SETBACK LINES, THE ENCROACHMENT OF  
PRIVATE YARDS INTO THE LANDSCAPE BUFFER,  
AND REDUCING THE CENTERLINE DRIVEWAY  
SPACING ALONG ROADWAY**

**CITY OF CORINTH, TEXAS  
ORDINANCE NO. 23-05-18-19**

**QUARRY MULTI-FAMILY PLANNED DEVELOPMENT DISTRICT #66**

**AN ORDINANCE OF THE CITY OF CORINTH, TEXAS, AMENDING THE CITY’S ZONING ORDINANCE AND THE “OFFICIAL ZONING DISTRICT MAP OF THE CITY OF CORINTH, TEXAS,” EACH BEING A PART OF THE UNIFIED DEVELOPMENT CODE OF THE CITY OF CORINTH, BY AMENDING THE ZONING CLASSIFICATION FOR THE PROPERTY DESCRIBED IN EXHIBIT “A,” ATTACHED HERETO AND INCORPORATED HEREIN, FROM SF-2 SINGLE FAMILY RESIDENTIAL TO PD-PLANNED DEVELOPMENT ZONING DISTRICT WITH A BASE ZONING DESIGNATION OF MF-1, MULTI-FAMILY RESIDENTIAL ON APPROXIMATELY 9.007 ACRES IDENTIFIED AS QUARRY MULTI-FAMILY PLANNED DEVELOPMENT DISTRICT NO. 66 (“PD-66”); PROVIDING A LEGAL PROPERTY DESCRIPTION; PROVIDING A GRAPHIC DEPICTION OF THE SITE TO BE REZONED (EXHIBIT “B”) APPROVING PLANNED DEVELOPMENT STANDARDS (EXHIBIT “C”); APPROVING A PLANNED DEVELOPMENT CONCEPT PLAN (EXHIBIT “D”); APPROVING A CONCEPTUAL LANDSCAPE PLAN (EXHIBIT “E”); APPROVING ELEVATIONS (EXHIBIT “F” (“F-1 – F-8”)); APPROVING AN OPEN SPACE EXHIBIT (EXHIBIT “G”); PROVIDING FOR THE INCORPORATION OF PREMISES; PROVIDING FOR A PENALTY NOT TO EXCEED \$2,000 A DAY FOR EACH VIOLATION OF THE ORDINANCE AND A SEPARATE OFFENSE SHALL OCCUR ON EACH DAY THAT A VIOLATION OCCURS OR CONTINUES; PROVIDING A CUMULATIVE REPEALER CLAUSE; PROVIDING A SEVERABILITY CLAUSE; PROVIDING A SAVINGS/CONFLICT CLAUSE; PROVIDING FOR PUBLICATION AND AN EFFECTIVE DATE.**

WHEREAS, the City of Corinth, Texas has adopted a Unified Development Code of the City as part of its Code of Ordinances, which includes the Comprehensive Zoning Ordinance and which, in accordance with the City’s Comprehensive Plan, establishes zoning districts and adopts a Zoning Map; and

WHEREAS, the property is comprised of a tract of land, approximately 9.007 acres as described in Exhibit “A” (the “Property”) and depicted in Exhibit “B” (the “Graphic Depiction”), and is currently zoned as SF-2 Single Family Residential, under the City’s Unified Development Code and as designated on the City’s Zoning Map; and

WHEREAS, an authorized person having a proprietary interest in the Property (the “Applicant”) has requested a change in the zoning classification of said Property to a PD-Planned Development zoning district with a base zoning of MF-1 Multi-Family Residential under the City’s Unified Development Code (“UDC”), more specifically identified as Quarry Multi-Family Planned Development District No. 66 (“PD-66”); and

WHEREAS, the City Council and the Planning and Zoning Commission of the City of Corinth, having given the requisite notices by publication and otherwise, and each, held due hearings and afforded a full and fair hearing to all the property owners generally, and to the persons interested and situated in the affected area and in the vicinity thereof; and

**WHEREAS**, the Planning and Zoning Commission has recommended approval of the requested change in zoning to the Property, and the City Council has determined that the Property has unique characteristics and that zoning through a planned development district is the most appropriate mechanism for zoning the Property, thus an amendment to the Comprehensive Zoning Ordinance and the Zoning Map of the City’s Unified Development Code, in accordance with the standards and specifications set forth herein, including without limitation the Planned Development Standards set forth in **Exhibit “C”** should be approved; and

**WHEREAS**, the City Council considered the following factors in making a determination as to whether the requested change should be granted or denied: safety of the motoring public and pedestrians using the facilities in the area immediately surrounding the sites; safety from fire hazards and damages; noise producing elements and glare of the vehicular and stationary lights and effect of such lights on established character of neighborhoods; location, and types of signs and relation of signs to traffic control and adjacent property; street size and adequacy of width for traffic reasonably expected to be generated by the proposed use around the site and in the immediate neighborhood; adequacy of parking as determined by requirements of this ordinance for off-street parking facilities; location of ingress and egress points for parking and off-street loading spaces, and protection of public health by surfacing on all parking areas to control dust; effect on the promotion of health and the general welfare; effect on light and air; effect on the over-crowding of the land; effect on the concentration of population, and effect on transportation, water, sewerage, schools, parks and other public facilities; and

**WHEREAS**, the City Council further considered among other things the character of the proposed district and its peculiar suitability for particular use requested and the view to conserve the value of the buildings, and encourage the most appropriate use of the land throughout this City; and

**WHEREAS**, the City Council finds that the requested Amendment to the City’s Comprehensive Zoning Ordinance and Zoning Map to effect the change in zoning for the Property to PD-66 promotes the health and the general welfare, provides adequate light and air, prevents the over-crowding of land, avoids undue concentration of population, and facilitates the adequate provision of transportation, water, sewerage, schools, parks and other public requirements; and the general health, safety and welfare of the community;

**NOW, THEREFORE, BE IT ORDAINED BY THE CITY COUNCIL OF THE CITY OF CORINTH, TEXAS:**

**SECTION 1.  
INCORPORATION OF PREMISES**

The above and foregoing recitals constitute legislative findings of the City Council, are true and correct and are incorporated into the body of this Ordinance for all purposes.

**SECTION 2.  
LEGAL PROPERTY DESCRIPTION; AMENDMENT**

That the Unified Development Code of the City of Corinth (“UDC”), which UDC includes the Comprehensive Zoning Ordinance that establishes zoning districts in accordance with the City’s Comprehensive Plan, and adopts the Zoning Map of the City of Corinth, is hereby amended to change the zoning classifications on approximately 9.007 acres of land, the overall boundary and legal description as specifically described in **Exhibit “A,”** attached hereto and incorporated herein (the “Property”), and as graphically depicted in **Exhibit “B,”** attached hereto and incorporated herein (the “Graphic Depiction”), from SF-2 Single Family Residential to PD-Planned Development zoning district with a base zoning of MF-1, Multi-Family Residential, and identified as Quarry Multi-Family Planned Development District

No. 66 (“PD-66”) subject to the regulations contained in this Ordinance, including without limitation **Exhibit “C”**, (the “Planned Development Standards”) as further described in Section 5 below. The Zoning Map of the City is also hereby amended to reflect the new zoning classification for the Property as PD-66 in accordance with this Ordinance.

**SECTION 3.  
PLANNED DEVELOPMENT CONCEPT PLAN**

The Planned Development Concept Plan for the Property as set forth in **Exhibit “D,” “Planned Development Concept Plan,”** a copy of which is attached hereto and incorporated herein, is hereby approved.

**SECTION 4.  
ADDITIONAL ANCILLARY CONCEPTUAL PLANS**

Additional ancillary conceptual plans apply to the Property and shall be adhered to in the development and use of the Property. Such additional and ancillary conceptual plans are set forth in the Conceptual Landscape Plan (**“Exhibit E”**), Elevations (**“Exhibit “F” (“F-1 – F-8”)**), and Open Space Exhibit (**“Exhibit “G”**), are attached hereto and incorporated herein, and are collectively herein referred to as the **“Ancillary Conceptual Plans.”**

**SECTION 5.  
LAND USE REGULATIONS/ZONING MAP**

A. The Zoning and Planned Development Standards set forth in **Exhibit “C,”** attached hereto and made a part hereof for all purposes are hereby adopted and shall be adhered to in their entirety for the purposes of this PD-Planned Development zoning district (“PD-66”) with a base zoning of MF-1, Multi-Family Residential. In the event of conflict between the provisions of **Exhibit “C”** and provisions of any other City zoning regulations, including without limitation, the regulations governing the MF-1, Multi-Family Residential zoning district, **Exhibit “C”** shall control. Except in the event of a conflict as provided herein or as otherwise expressly provided herein, all UDC regulations shall apply to the Property and shall be cumulative.

B. That the zoning regulations and district herein established for the Property has been adopted in accordance with the Comprehensive Plan for the purpose of promoting the health, safety, morals and the general welfare of the community. They have been designed, with respect to both present conditions and the conditions reasonably anticipated to exist in the foreseeable future; to lessen congestion in the streets; to provide adequate light and air; to prevent over-crowding of land; to avoid undue concentration of population; and to facilitate the adequate provision of transportation, water, sewerage, drainage and surface water, parks and other commercial needs and development of the community. They have been made after a full and complete hearing with reasonable consideration among other things of the character of the district and its peculiar suitability for the particular uses and with a view of conserving the value of buildings and encouraging the most appropriate use of land throughout the community.

C. The Planned Development Standards (**“Exhibit C”**), the Planned Development Concept Plan (**“Exhibit D”**), the Conceptual Landscape Plan (**“Exhibit E”**), the Elevations (**“Exhibits “F” (“F-1 – F-8”)**), and the Open Space Exhibit (**“Exhibit G”**) shall control the use and development of the Property in accordance with the provisions of this Ordinance, and all building permits and development requests shall be in accordance with applicable City ordinances, the PD Concept Plan, and the Ancillary Conceptual Plans. This Ordinance and all Exhibits hereto shall remain in effect as set forth herein unless amended by the City Council, or as otherwise provided for in UDC Subsection 2.10.09, Minor PD Amendment or Adjustment, as amended.



D. If a change to this Ordinance, including without limitation, the PD Concept Plan, and/or associated Ancillary Conceptual Plans, if any, is requested for the Property, the request shall be processed in accordance with the UDC and other development standards in effect at the time the change is requested for the proposed development and shall be subject to City Council approval, or as otherwise provided for in UDC Subsection 2.10.09, Minor PD Amendment or Adjustment, as amended.

E. The official Zoning Map of the City of Corinth, Texas shall be amended in accordance with this Ordinance to document the change in zoning for the Property from SF-2 Single Family Residential to PD-Planned Development Zoning District with a Base Zoning Designation of MF-1 Multi-Family Residential and identified as Quarry Multi-Family Planned Development District No. 66 (“PD-66”).

## **SECTION 6. CUMULATIVE REPEALER**

This Ordinance shall be cumulative of all other Ordinances and shall not repeal any of the provisions of such Ordinances except for those instances where there are direct conflicts with the provisions of this Ordinance. Ordinances, or parts thereof, in force at the time this Ordinance shall take effect and that are inconsistent with this Ordinance are hereby repealed to the extent that they are inconsistent with this Ordinance. Provided however, that any complaint, action, claim or lawsuit which has been initiated or has arisen under or pursuant to such other Ordinances on this date of adoption of this Ordinance shall continue to be governed by the provisions of such Ordinance and for that purpose the Ordinance shall remain in full force and effect.

## **SECTION 7. SEVERABILITY**

If any section, subsection, clause, phrase, or provision of this Ordinance, or the application thereof to any person or circumstance, shall to any extent be held by a court of competent jurisdiction to be invalid, void, or unconstitutional, the remaining sections, subsections, clauses, phrases, and provisions of this Ordinance, or the application thereof to any person or circumstance, shall remain in full force and effect and shall in no way be affected, impaired or invalidated.

## **SECTION 8. SAVINGS/CONFLICT**

In the event of a direct conflict between the provisions of this Ordinance and any other regulation or rule prescribed by charter, another ordinance, resolution or other authorization of the City, the provisions of this ordinance shall control. Notwithstanding the foregoing, all rights and remedies of the City are expressly saved as to any and all complaints, actions, claims, or lawsuits, which have been initiated or have arisen under or pursuant to such conflicting Ordinance, or portion thereof, on the date of adoption of this Ordinance shall continue to be governed by the provisions of that Ordinance and for that purpose the conflicting Ordinance shall remain in full force and effect.

## **SECTION 9. PENALTY FOR VIOLATIONS**

Any person, firm, or corporation who intentionally, knowingly or recklessly violates any provision of this Ordinance or the Code of Ordinances, as amended hereby, shall be subject to a fine not to exceed the sum of five hundred dollars (\$500.00) for each offense, and each and every day any such offense shall continue shall be deemed to constitute a separate offense, provided, however, that in all cases involving violation

of any provision of this Ordinance or Code of Ordinances, as amended hereby, governing the fire safety, zoning, or public health and sanitation shall be subject to a fine not to exceed the sum of two thousand dollars (\$2,000.00) for each offense, and each and every day any such offense shall continue shall be deemed to constitute a separate offense.

**SECTION 10.  
PUBLICATION/EFFECTIVE DATE**

This Ordinance shall take effect upon its publication as required by law. The City Secretary is directed to publish the caption and penalty of this Ordinance as required by the City Charter and state law.

**PASSED AND APPROVED BY THE CITY COUNCIL OF THE CITY OF CORINTH THIS 18<sup>th</sup> DAY OF MAY, 2023.**

APPROVED:

DocuSigned by:  
*Bill Heidemann*  
AC74FAA88CA6468...  
\_\_\_\_\_  
Bill Heidemann, Mayor

ATTEST:

DocuSigned by:  
*Lana Wylie*  
D77DD89FB0C3473...  
\_\_\_\_\_  
Lana Wylie, City Secretary



**APPROVED AS TO FORM:**

DocuSigned by:  
*Patricia Adams*  
B5BAF55D871D428...  
\_\_\_\_\_  
Patricia A. Adams, City Attorney

**EXHIBIT "A"**  
**LEGAL DESCRIPTION**

BEING a 392,365 square foot (9.007 acre) tract of land situated in the B.B.B. & C.R.R. Survey, Abstract No. 153, the M.E.P. & P.R.R. Survey, Abstract No. 915, the E. Marsh Survey, Abstract No. 833, and the Brooks Beall Survey, Abstract No. 58, same being those certain tracts of land conveyed to WILLIAM ANNESSER & Joan Annesser by Deed recorded in Volume 823, Page 128, Deed Records, Denton County, Texas, and WILLIAM L. ANNESSER & JOAN H. ANNESSER by Deed recorded in Volume 2315, Page 131, Deed Records, Denton County, Texas, and 1.128 acres out of those certain tracts of land conveyed to John B. Arnold by Deed recorded in Instrument Number 2006-34327, Deed Records, Denton County, Texas, and being more particularly described by metes and bounds as follows:

BEGINNING at a 1" Pipe Found at the northeast corner of said B.B.B. & C.R.R. Survey, Abstract No. 153 and the northwest corner of said M.E.P. & P.R.R. Survey, Abstract No. 915, same being in the south line of said Brooks Beall Survey, Abstract No. 58, from which a Concrete Monument bears North 39 degrees 49 minutes 40 seconds East, for 0.35 feet;

THENCE South 88 degrees 44 minutes 57 seconds East, along said south line, for a distance of 171.53 feet, to a Wooden Post Found, from which a 36" Oak Tree bears South 50 degrees 21 minutes 36 seconds, for 1.89 feet, same being the west line of said Brooks Beall Survey, Abstract No. 58, further being the east line of aforementioned E. Marsh Survey, Abstract No. 833;

THENCE North 00 degrees 05 minutes 24 seconds West, along said east and west lines, for a distance of 65.90 feet, to a 5/8" Iron Rod with Purple Plastic Cap Stamped, "RPLS 6451" Set for the most northern northwest corner of the herein described tract of land;

THENCE South 89 degrees 49 minutes 13 seconds East, for a distance of 121.00 feet, to a 5/8" Iron Rod with Purple Plastic Cap Stamped, "RPLS 6451" Set for the northeast corner of the herein described tract of land, same being in the westerly line of Parkridge Drive;

THENCE South 20 degrees 51 minutes 38 seconds East, along said Parkridge Drive, for a distance of 685.51 feet, to a 5/8" Iron Rod with Purple Plastic Cap Stamped, "RPLS 6451" Set for the southeast corner of the herein described tract of land, from which a 1/2" Iron Rod bears, North 20 degrees 51 minutes 38 seconds West, for 7.50 feet;

THENCE South 59 degrees 59 minutes 36 seconds West, departing said Parkridge Drive, for a distance of 203.15 feet;

THENCE South 24 degrees 59 minutes 38 seconds West, for a distance of 206.32 feet; THENCE South 60 degrees 53 minutes 16 seconds West, for a distance of 259.45 feet;

THENCE South 83 degrees 30 minutes 36 seconds West, for a distance of 72.42 feet, to a 5/8" Iron Rod with Purple Plastic Cap Stamped, "RPLS 6451" Set for the corner of the herein described tract of land.

THENCE North 01 degrees 26 minutes 33 seconds East, for a distance of 1,002.13 feet, to the POINT OF BEGINNING and containing 392,365 square feet or 9.007 acres of land, more or less.

### EXHIBIT "B" GRAPHIC DEPICTION

Exhibit B. -Proposed Zoning Map Change (SF-2 to PD with MF-1 Base)

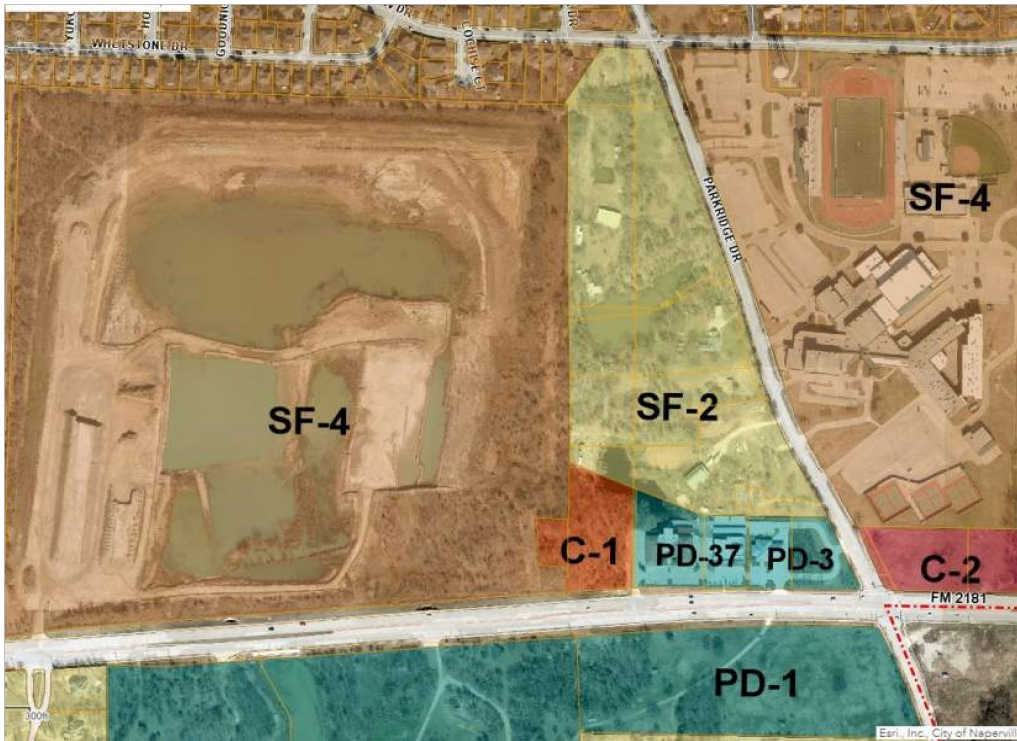

Existing Zoning Map

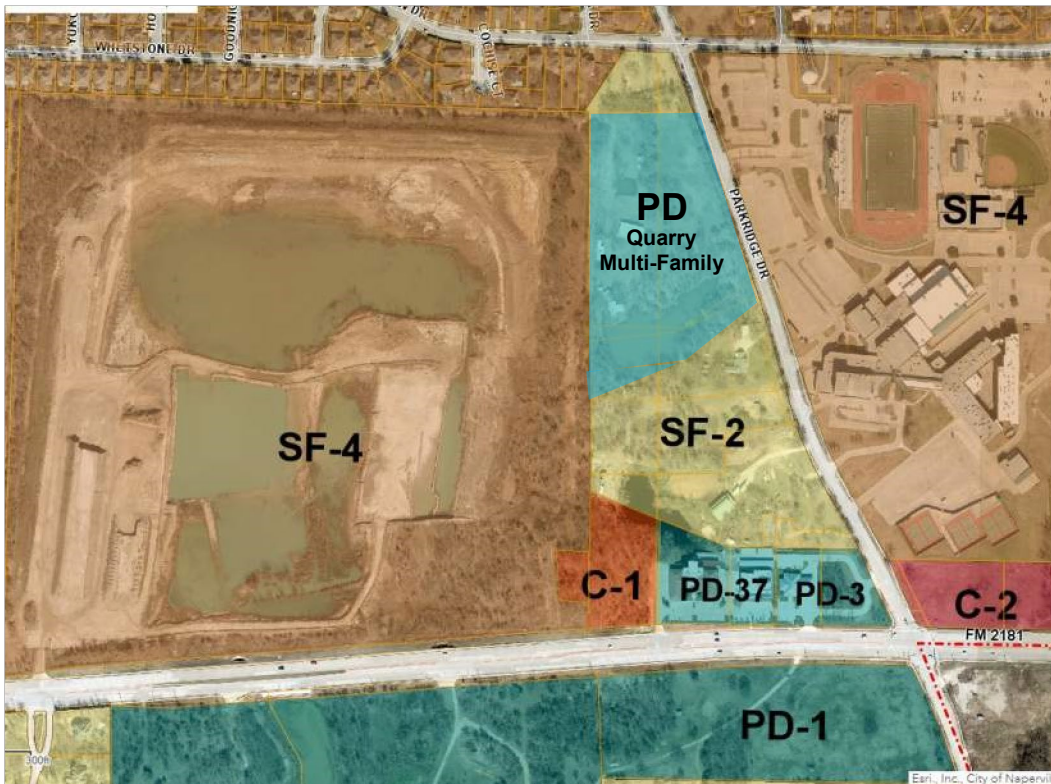

Proposed Zoning Map Change

**EXHIBIT “C”  
PLANNED DEVELOPMENT STANDARDS**

**SECTION 1: BASE DISTRICT**

**A. Purpose**

The regulations set forth in this **Exhibit “C”** provide development standards for multifamily residential uses within the Quarry Planned Development District No. 66 (“PD-66”). The boundaries of PD-66 are identified by metes and bounds on the Legal Description, **Exhibit “A”** to this Ordinance, and the Property shall be developed in accordance with these regulations and the Planned Development “PD” Concept Plan as depicted on **Exhibit “D”**, and associated Ancillary Concept Plans as depicted in **Exhibits “E”, “F, and “G”** to this Ordinance (collectively the foregoing are referred to as the “Development Standards”). A use that is not expressly authorized herein is expressly prohibited in this PD-66.

**B. Base District**

In this PD-66, the “MF-1” Multifamily Residential District regulations of the Corinth Unified Development Code, Ordinance No. 13-05-02-08, as amended, shall apply to the Property except as modified herein (hereinafter “UDC” or “Unified Development Code”). If a change to the PD Concept Plan, and/or associated Ancillary Concept Plans is requested, the request shall be processed in accordance with the UDC and development standards in effect at the time the change is requested for the proposed development per the Planned Development Amendment Process.

**SECTION 2: USES AND AREA REGULATIONS:**

The following items represent special development regulations, and specific departures or modifications, as well as waivers from the regulations outlined in Unified Development Code (UDC) in order to permit the unique design and afford flexibility and innovation of design that require certain departures from the “base zoning” regulations to create the unique type of residential “townhome” multi-family condominium project as presented in **Exhibit “D”** - PD Concept Plan and attached Ancillary Plans.

**A. Purpose**

The PD-66 District, “Quarry” is intended to provide for a quality development of a residential community taking advantage of the location and the concepts outlined in the Envision Corinth 2040 Comprehensive Plan by promoting variation in dwellings types, which includes a maximum of 90 multifamily (duplex-style and townhouse-style) units, as set forth on **Exhibit “D”** – PD Concept Plan, providing views and access to common open spaces and providing for passive neighborhood gathering spaces, maintaining a maximum gross density of ten (10) dwelling units per acre, and providing a community design that promotes walkability and social connection by linking the common open space areas located throughout the neighborhood.

**B. Permitted Use and Use Regulations**

In the PD-66 District, no building, or land shall be used, and no building shall be hereafter erected, reconstructed, enlarged, or converted unless otherwise provided for in the MF-1 Multifamily Residential District regulations of the Unified Development Code as modified or permitted by this PD Ordinance. The Permitted Uses in the MF-1 Multifamily Residential District as listed in Subsection 2.07.03 of the Unified

Development Code at the time of the adoption of this Ordinance shall be permitted in the PD-66 District, subject to applicable amendments adopted herein.

### C. Development Standards

Except as otherwise expressly set forth in these Development Standards, the regulations of Subsection 2.04.07, MF-1, Multifamily Residential of Subsection 2.04, “Residential Zoning Districts” of the Unified Development Code, for the MF-1 Multifamily District and all other requirements of the UDC shall apply to all development within PD-66.

### D. Dimensional Regulations

The Dimensional Regulations described in Subsection 2.08.04, “Residential Dimensional Regulations Chart” of Subsection 2.08, “Zoning Dimensional Regulations” of the Unified Development Code, for the base zoning district MF-1 Multifamily Residential shall apply, except as modified below:

1. **UDC Subsection 2.08 Dimensional Regulations** described for the MF-1 Multi-Family Residential District, shall apply, except as modified in Table A, below:

**Table A – Dimensional Requirements**

<b>Regulation</b>	<b>MF-1 Base District</b>	<b>Proposed Quarry Dimensional Standards</b>
Minimum Front Yard Setback	30’	30’
Minimum Side Yard Setback: Interior Lot	30’	30’
Corner Lot	30’	15’ (Along proposed Quarry Drive)
Minimum Rear Yard Setback	30’	30’
Minimum Separation Between Noncontiguous Attached Structures (UDC Table 2.08.04, Footnote [1])	30’	10’ (may be reduced to 8’ between certain units as generally depicted on Exhibit D - PD Concept Plan)
Residential Adjacency Standard	40’	40’
Minimum Lot Area	1 Acre	1 Acre
<b>Regulation</b>	<b>MF-1 Base District</b>	<b>Proposed Quarry Dimensional Standards</b>
Maximum Density	12 DU/A	10.0 DU/A (including ROW dedication) 10.69 DU/A (excluding ROW dedication)
Minimum Lot Width:	200’	200’
Minimum Lot Depth	200’	200’
Minimum Floor Area	1,050 sq. ft. per DU	889 sq. ft. per DU
Maximum Height (feet/stories)	35’/2 (50’ with additional Setback)	30’/2 (50’ with additional Setback)

Minimum Distance between front façades – Apartment Courts	30'	30'
Maximum Building Area (all buildings)	40%	45%

## E. Development Standards

1. **Accessory Building and Uses.** UDC Section 2.07.07 Accessory Building and Uses shall apply.
2. **Landscaping Regulations.** UDC Section 2.09.01 Landscape Regulations shall apply, except as modified below and as generally depicted **Exhibit “E”** - Conceptual Landscape Plan:
  - a. In addition to meeting the landscape regulations found in UDC Section 2.09.01, each unit shall be provided with Private, Fenced Yards. Each individual private fenced yard shall be a minimum of 175 square feet in area. For reference, see Figure 1, below.
  - b. UDC Section 2.09.01, Landscape Regulations B.1.k (i-iv), shall be modified as follows:
    1. 2.09.01.B.1.k., i. A twenty (20) foot landscape strip along the front of the buildings, shall be modified as follows: In lieu-of the required twenty (20) foot strip along the front of the buildings as measured from the foundation, every dwelling unit will have a ten (10) foot minimum fenced and gated private yard which opens into common open space with a central sidewalk connecting individual lead walks through the common area.
    2. 2.09.01.B.1.k., i. A twenty (20) foot landscape strip along the rear of the buildings, shall be modified as follows: In lieu-of the required twenty (20) foot strip along the rear of the buildings as measured from the foundation, every dwelling unit will have private alley accessible rear entry, covered garages.
    3. 2.09.01.B.1.k., ii. A fifteen (15) foot landscape strip along all other sides of the buildings, shall be modified as follows: In lieu-of the required fifteen (15) foot strip along the sides of the buildings as measured from the foundation, every building shall be separated by a minimum of eight (8) feet between duplexes.
    4. As provided for by 2.09.01.B.1.d. and to supplement the modifications to 2.09.01.B.k(i-iv) described in items 1-3 above, the Applicant/Developer shall provide shade trees, ornamental trees, foundation plantings, and private yard fencing as follows:
      - i. Shade Trees shall be provided at a minimum rate of one (1) per every two (2) duplex-style units staggering the shade trees along the internal central sidewalk within the open space.
      - ii. Ornamental Trees shall be at a minimum rate of one (1) per townhouse-style unit and one (1) per every two (2) duplex-style units.
      - iii. Foundation plantings shall be provided for each dwelling unit façade at a minimum rate of five (5) shrubs (deciduous and/or evergreen).
      - iv. Foundation plantings shall be provided at a minimum rate of one (1) ornamental tree and twelve (12) shrubs (evergreen) per 30 linear feet of façade length along the sides of dwelling units along Quarry Drive and along the sides of all townhouse style end units. Plant material may be grouped to create visual interest and rhythm along the streetscape.
      - v. A four (4) foot ornamental iron fence shall be provided for each dwelling unit façade as generally depicted on Exhibit “D” – PD Concept Plan and as illustrated in Figure 1, below.
  - c. 2.09.05.C.1, a. A double row of trees on offset 50-foot centers shall be planted in a fifteen (15) foot landscape edge, where 50% of the trees are Large Evergreen Trees; such trees



shall be planted to provide a buffer between the non-residential use and adjacent detached single family zoned properties. Trees shall be a minimum of three (3) caliper inches diameter at breast height "DBH" and shall be at least ten (10) feet in height.

**Figure 1 – Private Front Yard Illustration**

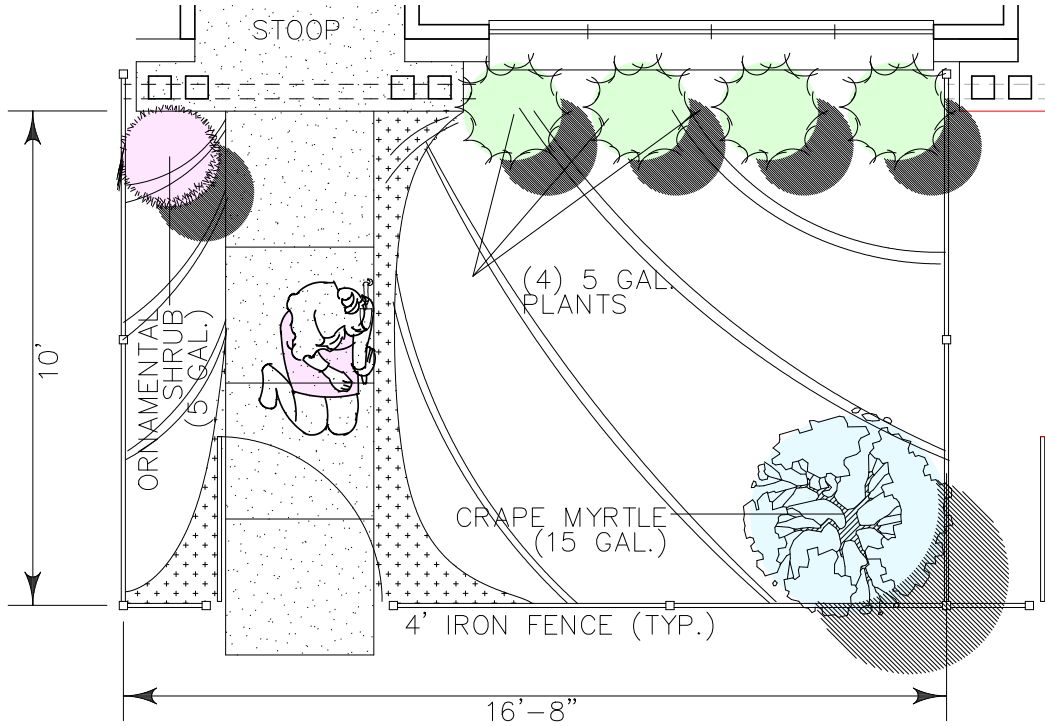

- 3. Tree Preservation.** UDC Subsection 2.09.02 Tree Preservation Regulations shall apply. The Applicant/Developer may request Alternative Compliance from the provisions of this section at the time of Site Plan submittal.

**Examples of Proposed Tree Preservation Areas**



View from Westmost Lake Lookout Dock to lake.





Dense Trees along Parkridge Drive Property Line to be preserved.

- 4. **Vehicular Parking Regulations.** UDC Section 2.09.03. Vehicular Parking Regulations shall apply, except as modified below.
  - a. Subsection 2.09.03.D.2, Parking Space Schedule: Multi-Family Uses, shall be modified to the standards set forth in Table B, below:

**Table B - Parking Requirements**

<b>Regulation</b>	<b>MF-1 Base Regulations by Use</b>	<b>Proposed Parking Standards/Modifications</b>
Parking Standard	1 space per DU + 1 space per bedroom	2.0 Spaces per 2-Bedroom 2.5 Spaces per 3-Bedroom

- b. Applicant/Developer shall provide a minimum of 206 parking spaces, comprised of 46, 1-car covered garages, 44, 2-car parking garages which total 134 covered parking spaces, and 72 surface parking spaces.
  - c. Additionally, the installation of on-street parking spaces on Quarry Drive shall be allowed. On-street parking spaces shall not be permitted to count towards the required parking count.
  - d. Temporary parking adjacent to the mailbox area including one (1) standard and one (1) accessible space shall be provided in Phase 1.
- 5. **Garages, Driveways, and Parking.** Section 2.04.07.C.5 requiring that “a minimum of seventy-five (75) percent of all apartments shall have a one-car enclosed garage, 240 square feet minimum, attached or detached, per dwelling unit”, shall apply as modified below:
  - a. All dwelling units shall be provided with private, attached one-car or two-car garages, 240 square feet minimum.

6. **Building Façade Material Standards.** UDC Section 2.09.04 Building Façade Material Standards shall apply. Building Façade Materials proposed to be used are described below:
  - a. Exterior façade materials shall consist of 100% masonry; the term “Masonry” shall be defined herein to include all cementitious siding products.
  - b. In addition, all front façade elevations shall be comprised of a minimum of 40% unit masonry, which shall including kiln fired brick and/or natural stone.
  - c. Additionally, side façade elevations for buildings siding onto public streets and access drives shall include a variety of materials and design elements as depicted on **Exhibit “F” (“F-1” to “F-8”)** – Elevations.
  - d. Exterior material percentage calculations shall be exclusive of all doors, windows, fascia, roofing, dormers, and areas contained within covered porches.
  
7. **Residential Adjacency Standards.** UDC Section 2.09.05 Residential Adjacency Standards shall apply.
  
8. **Private Recreation Areas.** UDC Section 2.04.07 shall apply, where a minimum of 8% of the gross complex area is required to be provided in the form of private recreation. The requirements of this section are in addition to the park dedication requirements within 3.05.10, Park and Trail Dedications for Residentially Zoned Property. To meet the Private Recreation requirements, the Quarry shall include the areas described in Table C, and as further enumerated below:

**Table C - Private Recreation Areas**

Private Recreation Areas	Percentage of Gross Complex Area*
Amenitized North Detention Pond (Lot 4X)	21,285 SF (5.80%)
Dog Park (Lot 3X)	4,417 SF (1.20%)
Four (4) Designated Lake Activity Nodes	5,776 SF (1.58%)
<b>TOTAL:</b>	<b>31,478 SF (8.58%)</b>

\*Gross Complex Area is exclusive of Quarry Drive right-of-way dedication.

- a. Specifically, the Applicant/Developer shall provide a minimum of 0.723 acres (31,478 sq. ft.) of amenitized private recreation open space including a landscaped North detention pond area buffer, dog park, picnic area, benches, and two dock outlooks adjacent to a private lake.
- b. The four (4) Lake Activity Nodes shall include, but are not limited to, the amenities presented in Figure 2, below:

**Figure 2 - Lake Activity Nodes Amenities:**



Four (4) 6’ Metal Frame Plaza Park Benches  
 Supplier: Uline or Equivalent (Item #H-8720)



One (1) ADA Accessible Metal Picnic Table 46” Round  
Supplier: Uline or Equivalent (Item #H-2672)



One (1) Outdoor Park Grill  
Supplier: Uline or Equivalent (Item #H-4419)

Note: Americans with Disabilities (ADA) access requirements will be met to the areas as depicted on the PD Concept Plan which includes the picnic table, one of two lake observation docks, and the double park bench seating area.

9. **Park and Trail Land Dedication.** UDC Section 3.05.10 requires that **Park and Trail dedication for Residentially Zoned Property** shall be provided at a rate of 1 acre per/50 DU and/or fees-in-lieu-of (or combination). The Applicant/Developer shall satisfy the requirements of Section 3.05.10 by providing the following, though there is no dedication to the City of Corinth, and all such amenities shall be privately maintained:
- a. Applicant/Developer shall be required to construct an eight-foot (8’) wide trail along the entire length of the west side of Parkridge Drive, 685.51’ in length (5,484 square feet). The width of this trail may be reduced to a minimum of five feet (5’) at time of Site Plan approval, should an alternative design or alignment be required for tree preservation or other purposes and should the City determine such alternative to be in the best interest of the public.
  - b. Applicant/Developer shall be required to construct an eight-foot (8’) wide trail along the entire length of the South side of the proposed Quarry Drive, 395.29’ in length (3,162 square feet).
  - c. Applicant/Developer shall be permitted to include the area of the trails constructed (length x width) in the calculation of the acreage required by this section.
  - d. The land area of Lake Recreation Lot 1X – excluding the land area of the four activity nodes contained within that Lot (which are designated as Private Recreation Areas) – shall be included in the calculations to meet the requirements of this section.

The Park and Trail Dedication shall be provided as described in Table D, below:

**Table D - Park and Trail Dedication**

<b>Park and Trail Dedication</b>	<b>Acreage</b>
8'-wide Trail – Parkridge Drive (L x W)	0.126
8'-wide Trail – Quarry Drive (L x W)	0.072
Lot 1X, not including Activity Nodes	2.359
REQUIRED PARK AND TRAIL DEDICATION (90 UNITS)	1.80
PROVIDED PARK AND TRAIL DEDICATION	2.557

10. **Screening of Outdoor Waste Storage for Nonresidential, Single-Family Attached, and Multi-Family Residential Properties.** UDC Section 4.02.13 shall apply.
11. **Lighting and Glare Regulations.** UDC Section 2.09.07 shall apply.
12. **Sign Regulations.** UDC Section 4.01 shall apply.
13. **Fence and Screening Regulations.** UDC Section 4.02. shall apply, except as modified below:
- Subsection 4.02.11 E [requiring a masonry wall], Residential Construction Abuts a Collector or an Arterial Street, shall not apply in order to create a heavily landscaped area fostering an open neighborhood feel which encourages walking and neighborhood interaction and connection to City of Corinth’s future trail network. Plantings shall be provided as described in Landscape Section above.
  - Specifically, the Applicant/Developer shall face front facades of multi-family “townhome” and “duplex style” dwelling units facing Parkridge Drive.
14. **Access Management.** UDC Section 3.05.04, Access Management, shall apply except as modified below:
- UDC 3.05.04.G 1. Driveway Dimensions and Spacing (City Maintained Roadways), Table 25: Dimensions for Driveways at City Maintained Roadways. Criteria: Minimum Centerline Driveway Spacing Along Roadway, Collector: 150 Feet, shall be modified to 120 feet to accommodate the design of the eastern most driveway locations along Quarry Drive thereby alleviating the requirement of an accessible gate requirement at those driveway entries.
15. **Miscellaneous Development Standards**
- Lake Overlook Guardrail.** A Lake Overlook Guardrail shall be installed in the area depicted on Conceptual Landscape Plan, and shall consist of the following elements and materials:
    - Stone Columns (4) feet minimum in height, spaced (14) feet maximum apart.
    - Horizontal Round Steel Tubing, (4) feet in height.
    - Iron Fence Posts ((3) inch x (3) inch), spaced (6) feet maximum apart.

**EXHIBIT "D"**  
**PLANNED DEVELOPMENT CONCEPT PLAN**



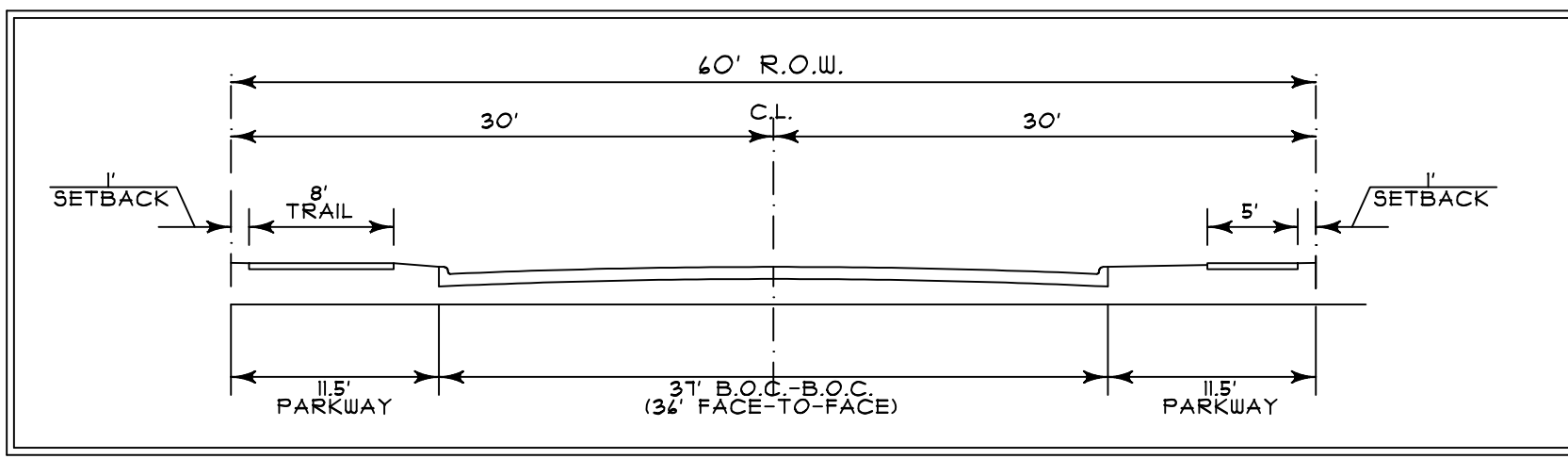

**FIRE SERVICE NOTES**

- 2018 INTERNATIONAL FIRE CODE, APPENDIX D, DIO.I MULTI-FAMILY RESIDENTIAL PROJECTS HAVING MORE THAN 100 DWELLING UNITS SHALL BE EQUIPPED THROUGHOUT WITH TWO SEPARATE AND APPROVED FIRE APPARATUS ACCESS ROADS.\*
- PROJECTS HAVING UP TO 200 DWELLING UNITS SHALL HAVE NOT FEWER THAN ONE APPROVED FIRE APPARATUS ACCESS ROAD WHERE ALL BUILDINGS INCLUDING NONRESIDENTIAL OCCUPANCIES, ARE EQUIPPED WITH AN APPROVED AUTOMATIC FIRE SPRINKLER SYSTEM.\*
- MAXIMUM BUILDING HEIGHT SHALL NOT EXCEED 30'.

**CONCEPT PLAN NOTES**

- ALL DIMENSIONS ARE TO FACE OF CURB UNLESS OTHERWISE NOTED.
- ALL FINAL ROAD ALIGNMENTS, EASEMENTS, BUILDING LOCATIONS, APERTITIES TO BE DETERMINED AT THE SITE PLAN PROCESS AND SHALL BE IN CONFORMANCE AS DEPICTED HEREIN (EXHIBIT "PD CONCEPT PLAN").
- ALL STANDARD PARKING SPACES TO BE 9'X18'.
- ALL PARALLEL PARKING SPACES TO BE 8'X22'.
- ALL PUBLIC TRAIL/SIDEWALK LOCATED ON PRIVATE PROPERTY TO BE LOCATED IN A PEDESTRIAN ACCESS EASEMENT.
- FINAL LANDSCAPE ALONG PARKRIDGE & QUARRY SHALL CONFORM TO APPLICABLE SITE DISTANCE VISIBILITY CRITERIA FOR PROPOSED ACCESS LOCATION.
- CONDOMINIUM AND/OR HOA DOCUMENTS SHALL REQUIRE RESIDENTS TO KEEP GARAGES FREE OF OBSTRUCTIONS AND REQUIRE RESIDENTS UTILIZE SUCH GARAGE PARKING IN ORDER TO MAINTAIN ACCESS TO GUEST PARKING.
- HOA WILL OFFER TRASH VALE PICKUP SERVICES FOR RESIDENTS A MINIMUM OF ONCE PER WEEK.

**ZONING COMPARISON TABLE**

	BASE	
	MF-2	PROP. PD
MINIMUM SETBACKS		
FRONT YARD	30'	30'
SIDE YARD	30'	30'
INTERIOR LOT	30'	30'
CORNER LOT	30'	15'
BETWEEN BUILDINGS	30'	10'
REAR YARD	40'	40'
RESIDENTIAL ADJACENCY STAND.	40'	30'
GARAGE	75% 1-Car Covered	100% 1 or 2 Car
MINIMUM LOT DIMENSIONS		
LOT AREA (SQ. FT.)	25,000	20,000
LOT WIDTH	200'	200'
LOT DEPTH	200'	200'
DENSITY (MAX. DU/A)	14	10.97
MINIMUM ATTACHED 1-CAR GARAGE		
ATTACHED GARAGES PER UNIT	75%	100%
ATTACHED 2-CAR GARAGES	N/R	44 EA/49% 46 EA/51%
RECREATION AREA REQUIREMENT		
RECREATION AREA (DOG PARK)	1	1
MINIMUM FLOOR AREA (SF PER DU)	950	886
MINIMUM FLOOR AREA (SF PER DU)	950	886
APARTMENT COURTS, UDC 2.04.08.c.9	30'	30'
MAX. BUILDING AREA (TOTAL)	45%	45%

**CONCEPT PLAN NOTES CON'T.**

- THE ACTUAL LOCATION OF THE PUBLIC STREET TERMINUS (DISTANCE FROM THE STREET TERMINUS LINE) AND BARRIADFE WILL BE DETERMINED AT TIME OF SITE PLAN BASED ON A DESIGN ACCEPTABLE TO THE CITY ENGINEER CONSIDERING TRAFFIC SAFETY AND OTHER FACTORS NECESSARY TO PROVIDE ADEQUATE NOTICE OF THE STREET TERMINUS UNTIL THE STREET BECOMES A THROUGH CONNECTION IN THE FUTURE.

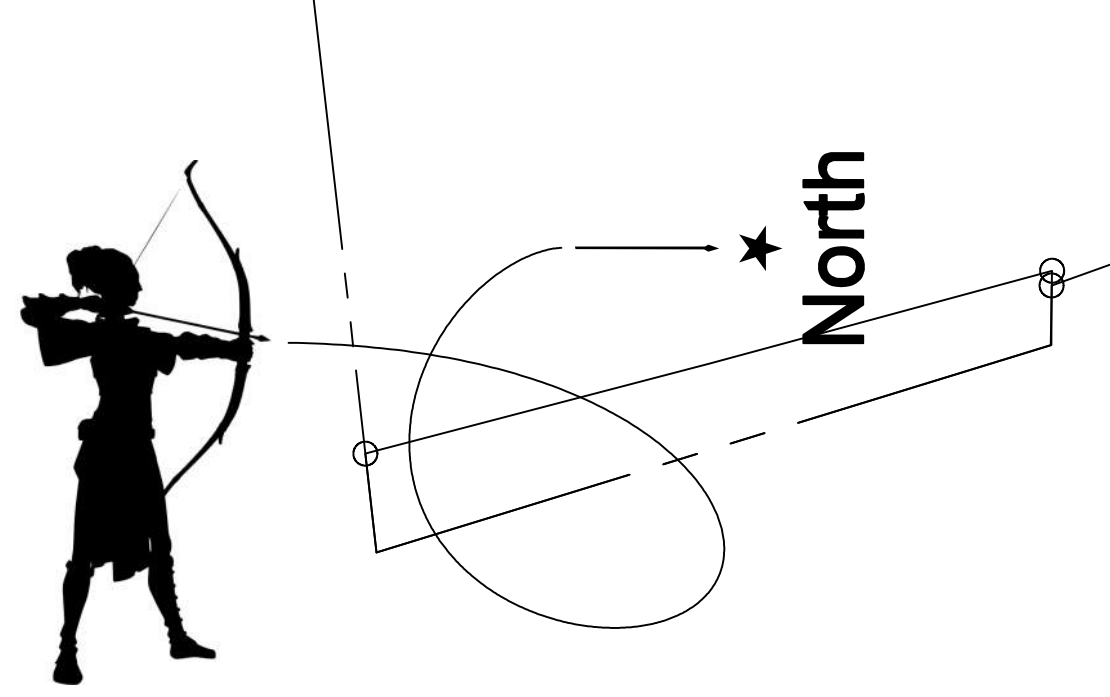

**OWNER/DEVELOPER:**  
 Rockbrook Development LLC  
 2104 Cosmos Way  
 Argyle, Texas 76226  
 Tel. No. (214) 454-1895  
 Contact: Jason Rose  
 jason@jrosearchitect.com

**PHASING PARKING SUMMARY**

PHASE 1			
PARKING REQUIRED:	UNITS	REQUIRED	
2-BEDROOM (2 SPACES REQ'D.)	30	60	
3-BEDROOM (2.5 SPACES REQ'D.)	30	75	
TOTALS:	60	135	
PARKING PROVIDED (BEST PRACTICES N. TEXAS):	PROVIDED		
GARAGE SPACES ATTACHED TO DWELLINGS	90		
ON-SITE SURFACE PARKING SPACES (NON H.C.)	43		
HANDICAP PARKING STALL(S)	2		
TOTAL PARKING PROVIDED:	135		
PARKING SPACES PER UNIT CALCULATION	(135/60)	=2.25	
PHASE 2			
PARKING REQUIRED:	UNITS	REQUIRED	
2-BEDROOM (2 SPACES REQ'D.)	16	32	
3-BEDROOM (2.5 SPACES REQ'D.)	14	35	
TOTALS:	30	67	
PARKING PROVIDED (BEST PRACTICES N. TEXAS):	PROVIDED		
GARAGE SPACES ATTACHED TO DWELLINGS	44		
ON-SITE SURFACE PARKING SPACES (NON H.C.)	27		
HANDICAP PARKING STALL(S)	0		
TOTAL PARKING PROVIDED:	71		
PARKING SPACES PER UNIT CALCULATION	(71/30)	=2.37	

**PD CONCEPT PLAN**  
 SCALE: 1"=40'-0"

**QUARRY MULTI-FAMILY CONDOMINIUM DEVELOPMENT**  
 9.00 ACRE TRACT OF LAND

A0833A E. MARSH, TR 21, 4.99 ACRES, OLD DCAD TR #1A  
 A0915A MEP & PRR, TR 6, 2.34 ACRES, OLD DCAD TR #3A(1)  
 A0915A MEP & PRR, TR 1A, 1.633 ACRES, (SURVEY: 1.623 ACRES)

1.385 ACRES OUT OF:  
 A0833A E. MARSH, TR 23(PT), 2.5944 ACRES, OLD DCAD TR #1A(2)#8A  
 A0833A E. MARSH, TR 22, 1.8 ACRES, OLD DCAD TR #1A(4)  
 A0915A MEP & PRR, TR 1, 9.261 ACRES, OLD DCAD TR #3A(1A)

**CITY OF CORINTH, DENTON COUNTY, TEXAS**  
 January 23, 2023

**SITE PLAN SUMMARY TABLE**

EXISTING ZONING/USE:	SF-2	
PROPOSED ZONING:	PD W/MF-2 BASE ZONING	
PROPOSED USE:	RESIDENTIAL "DUPLEX-STYLE" CONDOMINIUMS & "TOWNHOME-STYLE" CONDOMINIUMS	
NUMBER OF LOTS:	3 (EXISTING); 6 (PROPOSED)	
LOT AREA:	AC.	SQ. FT.
GROSS SITE	9,007	392,365
ROW DEDICATION	0,589	25,656
SOUTH LOT (LOT 1)	2,914	126,925
AMENITIZED NORTH DETENTION POND (LOT 4X)	0,489	21,285
NORTH LOT (LOT 2)	1,698	73,982
LAKE RECREATION LOT (LOT 1X)	2,690	117,175
SOUTH OPEN SPACE LOT (LOT 2X)	0,526	22,897
DOG PARK (LOT 3X)	0,101	4,417
3.05.10 PARK AND TRAIL DEDICATION:	AC.	SQ. FT.
(1) ACRE FOR EACH 50 DWELLING UNITS	90/50	78,408
PROVIDED (LAKE RECREATION LOT 1X):	2,690	117,175
LOT COVERAGE:	T.B.D.	
DENSITY:	10 UNITS / ACRE (EXCLUDING R.O.W. DED.)	
PROPOSED BUILDINGS (2 STORY):	AREA*	NO. BLDGS. NO. UNITS TOTAL
2-BEDROOM	889	- 46 40,894
3-BEDROOM	1,041	- 44 45,804
2-CAR GARAGE ATTACHED	404	- 44 17,776
1-CAR GARAGE ATTACHED	263	- 46 12,098
COVERED FRONT PORCHES	17 x 90	- 90 1,530
TOTALS:		90 118,102
AVERAGE DWELLING UNIT	965	- 90 118,102
PARKING REQUIRED:	UNITS	REQUIRED PROPOSED
2-BEDROOM (2 SPACES REQ'D.)	46	92
3-BEDROOM (2.5 SPACES REQ'D.)	44	110
TOTALS:	90	202 206
PARKING PROVIDED (BEST PRACTICES N. TEXAS):	PROVIDED	
GARAGE SPACES ATTACHED TO DWELLINGS	134	
ON-SITE SURFACE PARKING SPACES (NON H.C.)	70	
HANDICAP PARKING STALL(S)	2	
TOTAL PARKING PROVIDED:	206	
PARKING SPACES PER UNIT CALCULATION	(206/90)	=2.29
ATTACHED COVERED GARAGE SPACES PER UNIT:	29,337	8%* (SF. %)
PRIVATE RECREATION SPACE REQUIRED:		
AMENITIZED NORTH DETENTION POND (4X)	21,285	5.80%* (SF. %)
DOG PARK (LOT 3X)	4,417	1.77%* (SF. %)
DESIGNATED LAKE ACTIVITY NODES X4	5,776	1.58%* (SF. %)
TOTALS:	31,478	8.58%* (SF. %)
OPEN SPACE PROVIDED:		
LAKE RECREATION LOT DEDICATED LOT (1X)	117,175	31.95%* (SF. %)
SOUTH RECREATION LOT (2X)	22,897	6.24%* (SF. %)
MISC. COMMUNITY OPEN SPACE 1	32,723	8.92%* (SF. %)
TOTALS:	172,795	47.11%* (SF. %)
PRIVATE RECREATION SPACE PROVIDED:		
FENCED PRIVATE YARDS:	31,500	8.59%* (SF. %)
LANDSCAPE AREA:	230,025	62.73%* (SF. %)
IMPERVIOUS AREA:	136,684	37.27%* (SF. %)
LOADING SPACE:	NOT REQUIRED	
OUTSIDE STORAGE:	NONE PROPOSED	

\* PERCENTAGE IN RELATIONSHIP TO "NET" SITE =366,709 SF



**J Rose Architects & Planners**  
 2120 Cosmos Way  
 Argyle, TX 76226  
 (214) 454-1895 T.  
 jason@jrosearchitect.com



2-13-2023

**Consultants:**

Civil Engineer:  
 Oracle Engineering  
 Matt Kostial, P.E.  
 2204 Green Hill Drive  
 McKinney, TX 75070  
 (214) 226-5325 Tel.  
 mattkostial@sbcglobal.net

Surveyor:  
 Duenes Land Surveying, LLC  
 Dustin Davison, R.P.L.S.  
 2112 Blackfoot Trail  
 Mesquite, TX 75149  
 (214) 317-0685 Tel.  
 dustin@dueneslandsurveying.com

Geotechnical Engineer:  
 Rone Engineering  
 Mark D. Gray, P.E.  
 8908 Ambassador Row  
 Dallas, TX 75247 Tel.  
 (214) 630-9145 Tel.  
 mgray@roneengineers.com

**Project Title:**  
 Quarry

3000 Parkridge Dr.  
 Corinth, TX 76201

**Sheet Title:**  
 PD Concept Plan

**Drawn by:** JRR  
**Date Created:** 2-13-2023

**Revised on:** 2-13-2023

**Exhibit D**



**EXHIBIT “E”**  
**CONCEPTUAL LANDSCAPE PLAN**



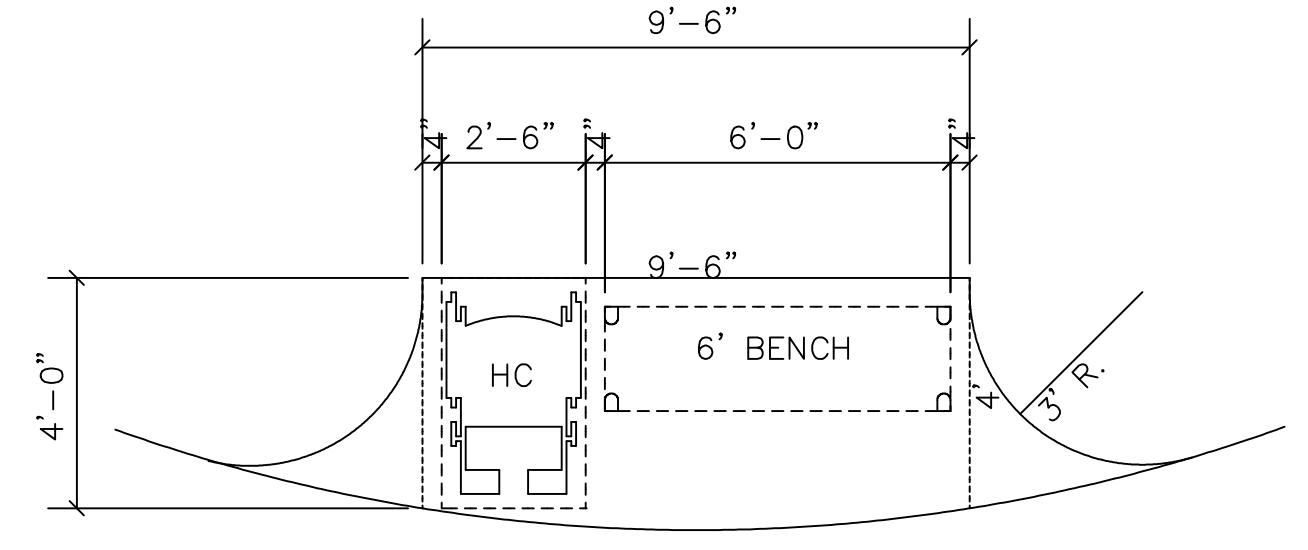

02 HANDICAP ACCESSIBLE SEATING BENCH AREA (TYP.)  
SCALE: 1" = 1'-0"

LANDSCAPE TABLE	
SOURCE: CORINTH UDC 2.09.01. - LANDSCAPING REGULATIONS	
2.09.01. B.1. MULTI-FAMILY	
LANDSCAPE BUFFER WIDTH ADJACENT TO COLLECTOR STREET	15'
LANDSCAPE EDGE TREES REQUIRED	SPACED EVERY 30' WHERE PRACTICAL 3" CALIPER 25 PROVIDED*
SIZE REQUIRED:	
SHRUB BUFFER FOR PARKING LOTS AND DRIVES WHERE ABOUT THE LANDSCAPE EDGE	CONTIGUOUS 5 GALLON
TWENTY SQUARE FEET OF LANDSCAPING PER 20 PARKING SPACE INCLUDING ONE 3" CAL. TREE	72 SURFACE PARKING SPACES 4 SHADE TREES REQUIRED 4 SHADE TREES PROVIDED
ONE 3" CAL. SHADE TREE PER 1,000 SQFT OF REQUIRED OPEN SPACE	29,337 SF/1,000 = 30 3" CAL. SHADE TREES 30 REQUIRED/30 PROVIDED
DOUBLE ROW OF TREES OFFSET FIFTY (50) FEET PLANTED IN FIFTEEN (15) FOOT LANDSCAPE EDGE	PROVIDED: 9 DECIDUOUS 11 EVERGREEN
FIFTY PERCENT (50%) OF THE TREES TO BE LARGE EVERGREEN TREES.	
2.09.05.C.1.a. RESIDENTIAL ADJACENCY STANDARDS WHERE NOT IN CONFLICT WITH EXISTING TREES	
SIZE REQUIRED:	3" CALIPER, MIN. 10' TALL



**J Rose Architects & Planners**  
2120 Cosmos Way  
Argyle, TX 76226  
(214) 454-7895 T.  
jason@jrosearchitect.com

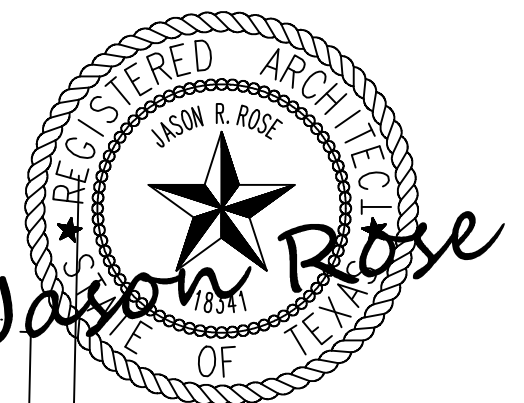

2-13-2023

**Consultants:**

Civil Engineer:  
Oracle Engineering  
Matt Kostial, P.E.  
2204 Green Hill Drive  
McKinney, TX 75070  
(214) 226-5325 Tel.  
mattkostial@sbcglobal.net

Surveyor:  
Duenes Land Surveying, LLC  
Dustin Davison, R.P.L.S.  
2112 Blackfoot Trail  
Mesquite, TX 75149  
(214) 317-0685 Tel.  
dustin@dueneslandsurveying.com

Geotechnical Engineer:  
Rone Engineering  
Mark D. Gray, P.E.  
8908 Ambassador Row  
Dallas, TX 75247 Tel.  
(214) 630-9745 Tel.  
mgray@roneengineers.com

**Project Title:**  
**Quarry**

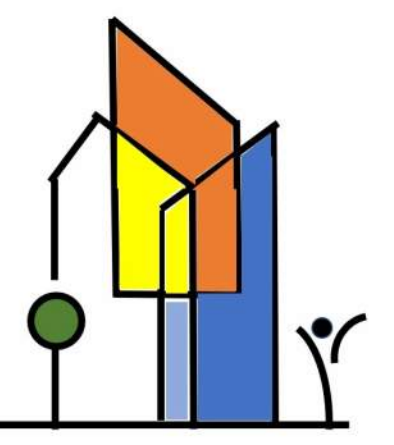

3000 Parkridge Dr.  
Corinth, TX 76201

**Sheet Title:**  
**Conceptual Landscape Plan**

Drawn by: JRR  
Date Created: 2-13-2023

SHEET

**Exhibit E**

Revised on: 2-13-2023

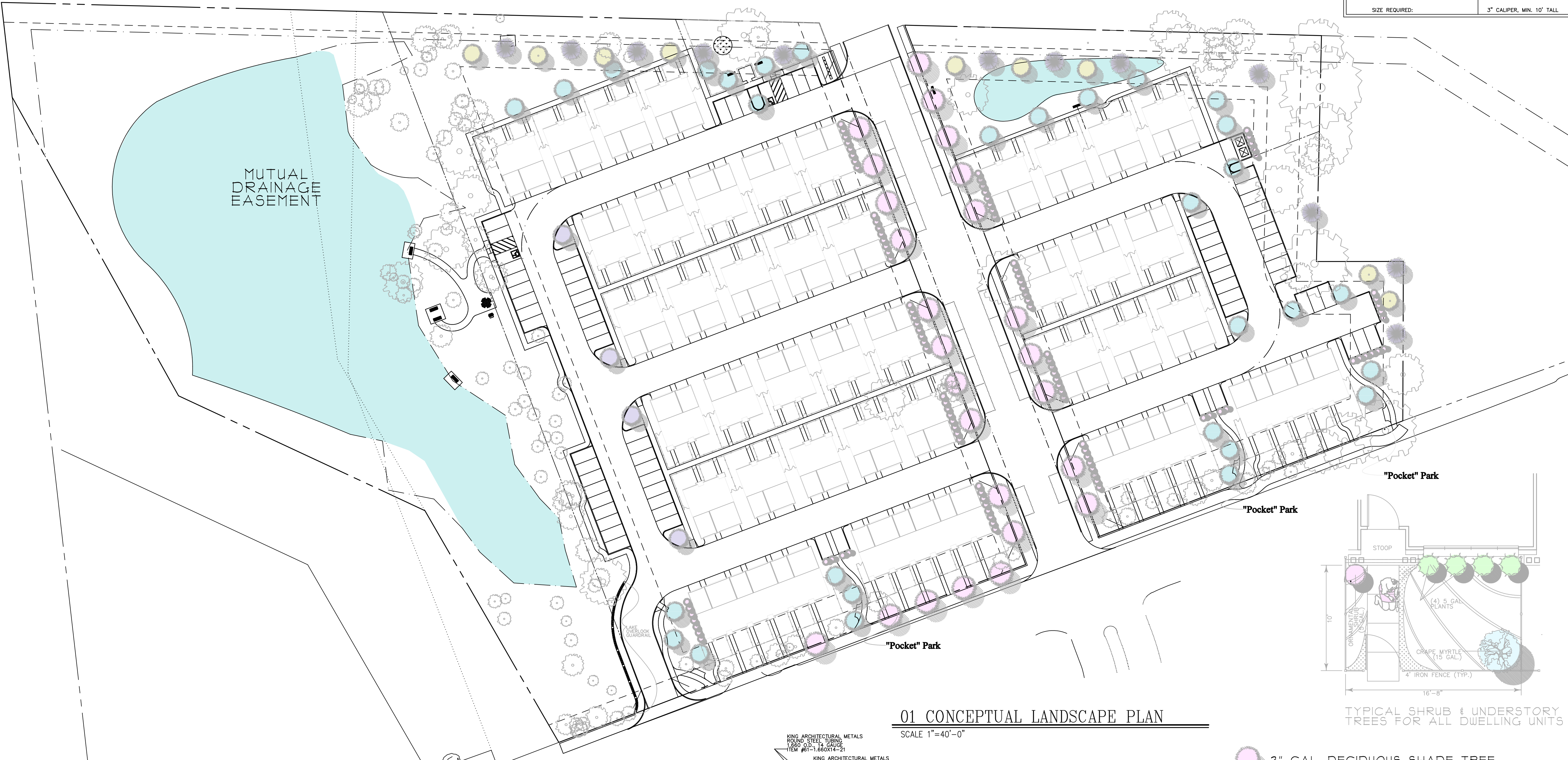

01 CONCEPTUAL LANDSCAPE PLAN  
SCALE 1"=40'-0"

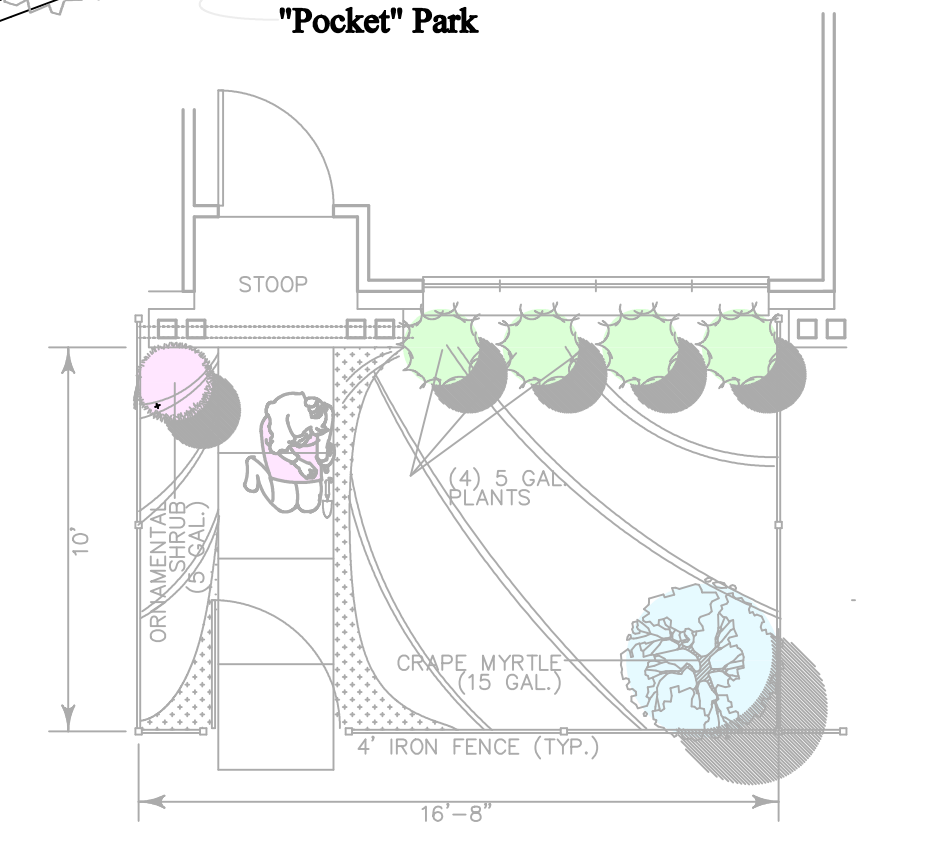

TYPICAL SHRUB & UNDERSTORY TREES FOR ALL DWELLING UNITS

- 3" CAL. DECIDUOUS SHADE TREE ADJACENT TO COLLECTOR STREET(S)
- 3" CAL. DECIDUOUS SHADE TREE (50% 15' LANDSCAPE EDGE REQUIREMENT) 9 EA
- 3" CAL. EVERGREEN TREE (50% 15' LANDSCAPE EDGE REQUIREMENT) 11 EA
- 3" CAL. SHADE TREE PER 1,000 SF OF OPEN SPACE REQUIREMENT 29,337/1,000 = 30 EA
- 3" CAL. SHADE TREE PER 20 PARKING LOT SPACES 12/20 = 4 EA

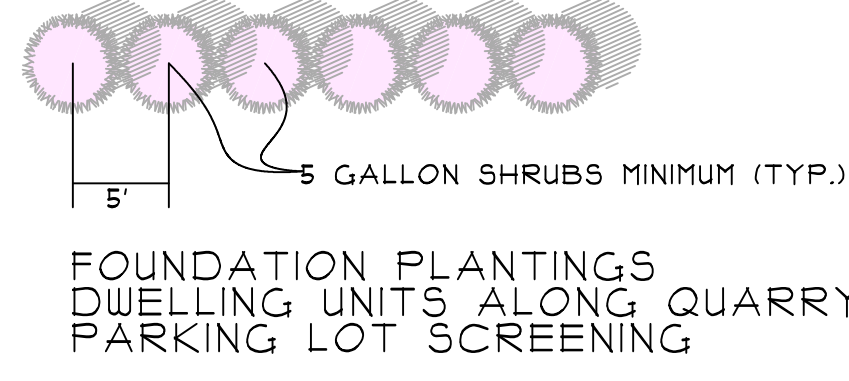

FOUNDATION PLANTINGS DWELLING UNITS ALONG QUARRY PARKING LOT SCREENING

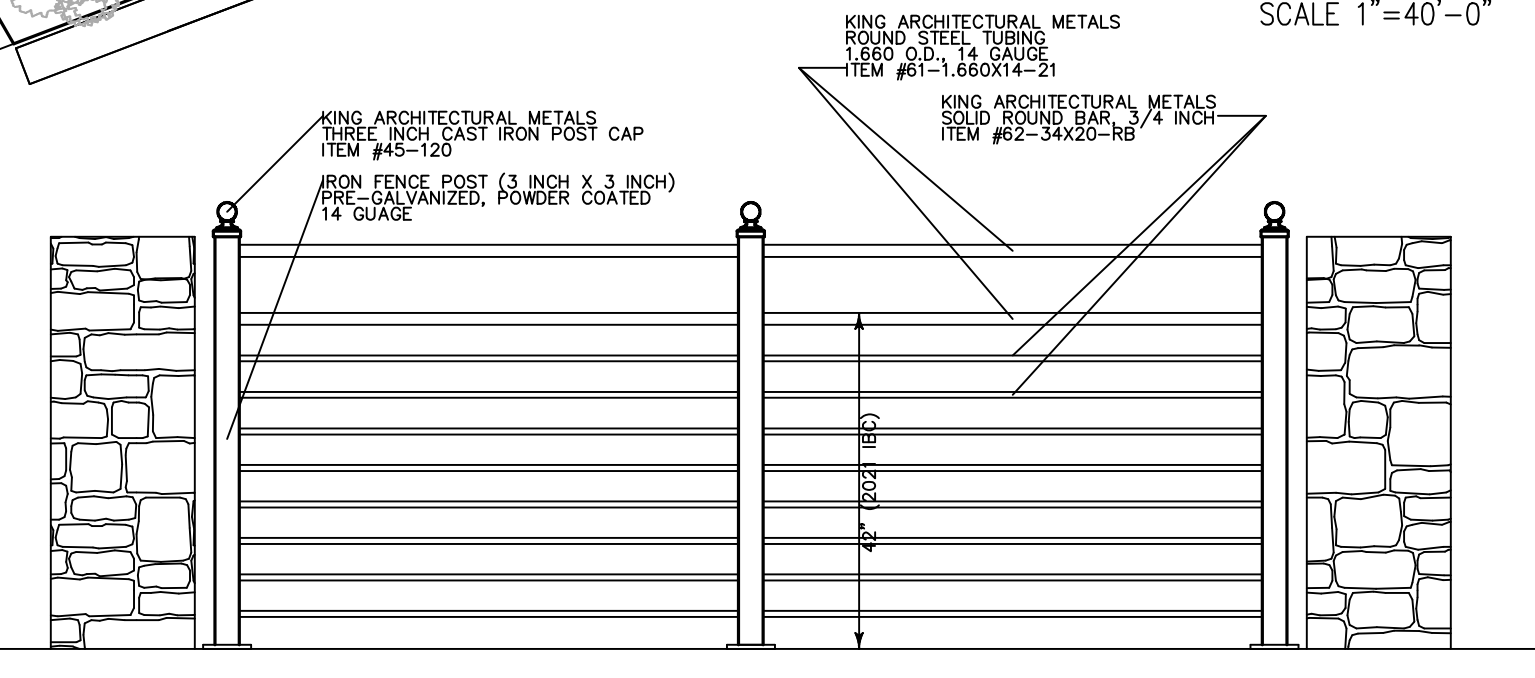

03 LAKE OVERLOOK GUARDRAIL DETAIL  
SCALE 1/2" = 1'-0"

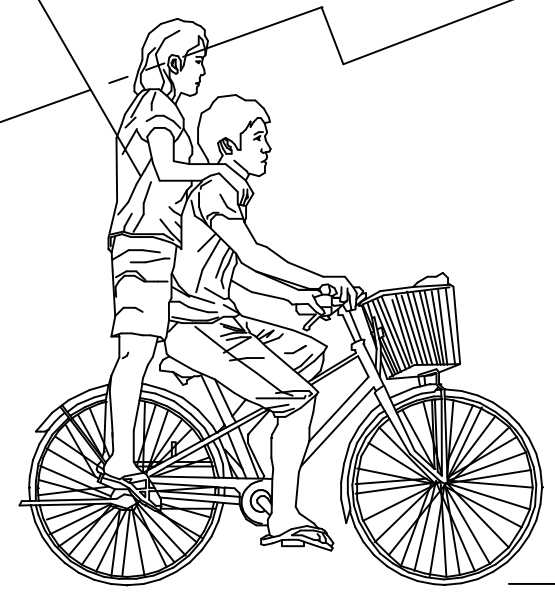
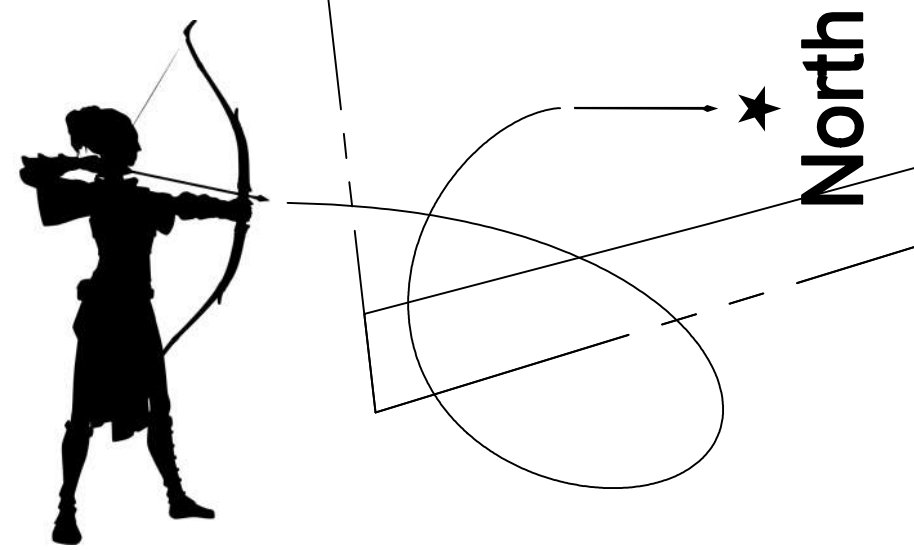



**EXHIBIT “F” (“F-1 through “F-8”)  
ELEVATIONS**





ACME BRICK  
KINGSIZE  
COLOR: "WINTERSTONE"



ACME BRICK  
KINGSIZE  
COLOR: "WHITE SAGE"



ACME BRICK  
KINGSIZE  
COLOR: "PINE RIDGE"

THE MOST POPULAR  
Farmhouse Paint Colors  
FOR THAT FIXER UPPER LOOK

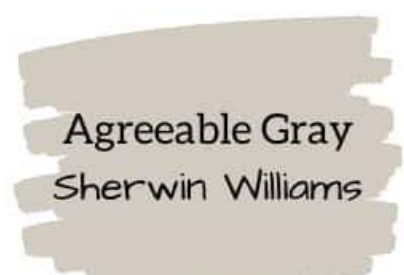
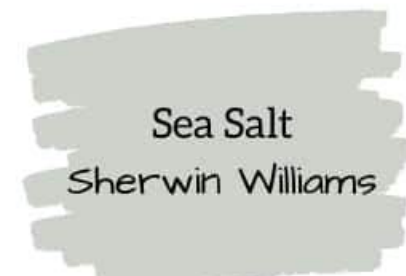
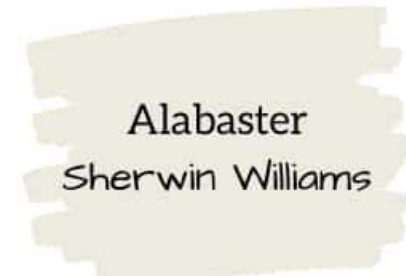
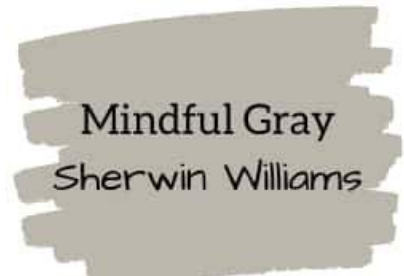

WWW.LIFEONSOUTHPOINTEDRIVE.COM



CEMENTITIOUS HARDIE  
TEXTURES

Front Facade Material Standards within  
the PD Narrative:  
Masonry: 100%\*  
Brick or Stone: Unit Masonry : 40%\*  
Cementitious Fiber: 60% -Maximum\*  
\*Exclusive of Doors & Windows

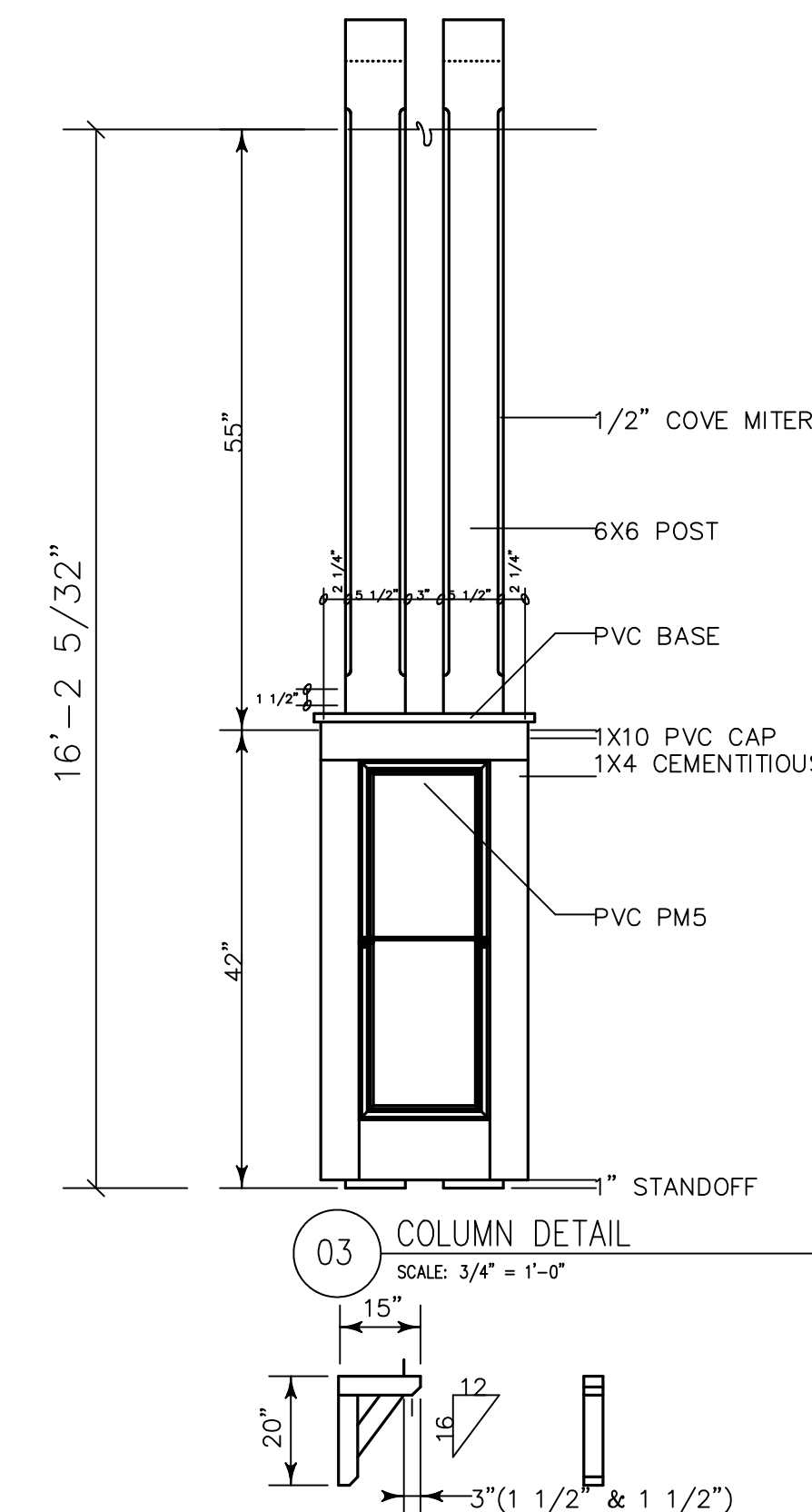

**J Rose  
Architects &  
Planners**  
2120 Cosmos Way  
Argyle, TX 76226  
(214) 454-7895 T.  
jason@jrosearchitect.com



2-13-2023

**Consultants:**

Civil Engineer:  
Oracle Engineering  
Matt Kostial, P.E.  
2204 Green Hill Drive  
McKinney, TX 75070  
(214) 226-5325 Tel.  
mattkostial@sbcglobal.net

Surveyor:  
Duenes Land Surveying, LLC  
Dustin Davison, R.P.L.S.  
2112 Blackfoot Trail  
Mesquite, TX 75149  
(214) 311-0485 Tel.  
dustin@dueneslandsurveying.com

Geotechnical Engineer:  
Rone Engineering  
Mark D. Gray, P.E.  
8908 Ambassador Row  
Dallas, TX 75241 Tel.  
(214) 630-9745 Tel.  
mgray@roneengineers.com

Project Title:  
**Quarry  
Residences**

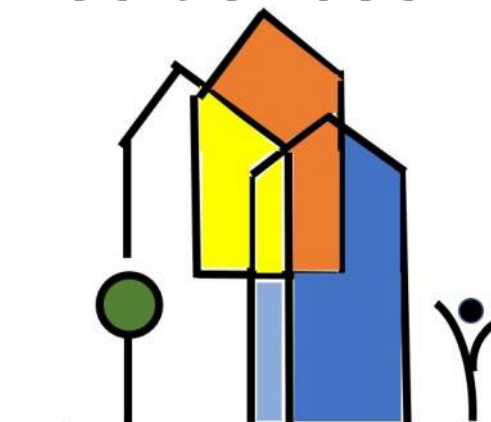

3000 Parkridge Dr.  
Corinth, TX 76201

Sheet Title:  
**Exhibit F  
Front  
Elevation**

Drawn by: JRR  
Date Created: 2-13-2023

SHEET

**Exhibit F-1**

Revised on: 2-13-2023



01 FRONT ELEVATION

SCALE 3/8"=1'-0"



01 FRONT ELEVATION

SCALE 3/8"=1'-0"

Scale: 1"=40'-0"

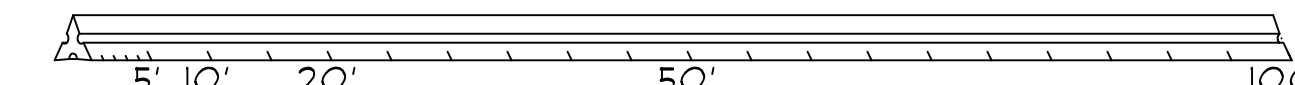

Revised on: 2-13-2023





ACME BRICK KINGSIZE COLOR: "WINTERSTONE"



ACME BRICK KINGSIZE COLOR: "WHITE SAGE"



ACME BRICK KINGSIZE COLOR: "PINE RIDGE"

THE MOST POPULAR Farmhouse Paint Colors FOR THAT FIXER UPPER LOOK

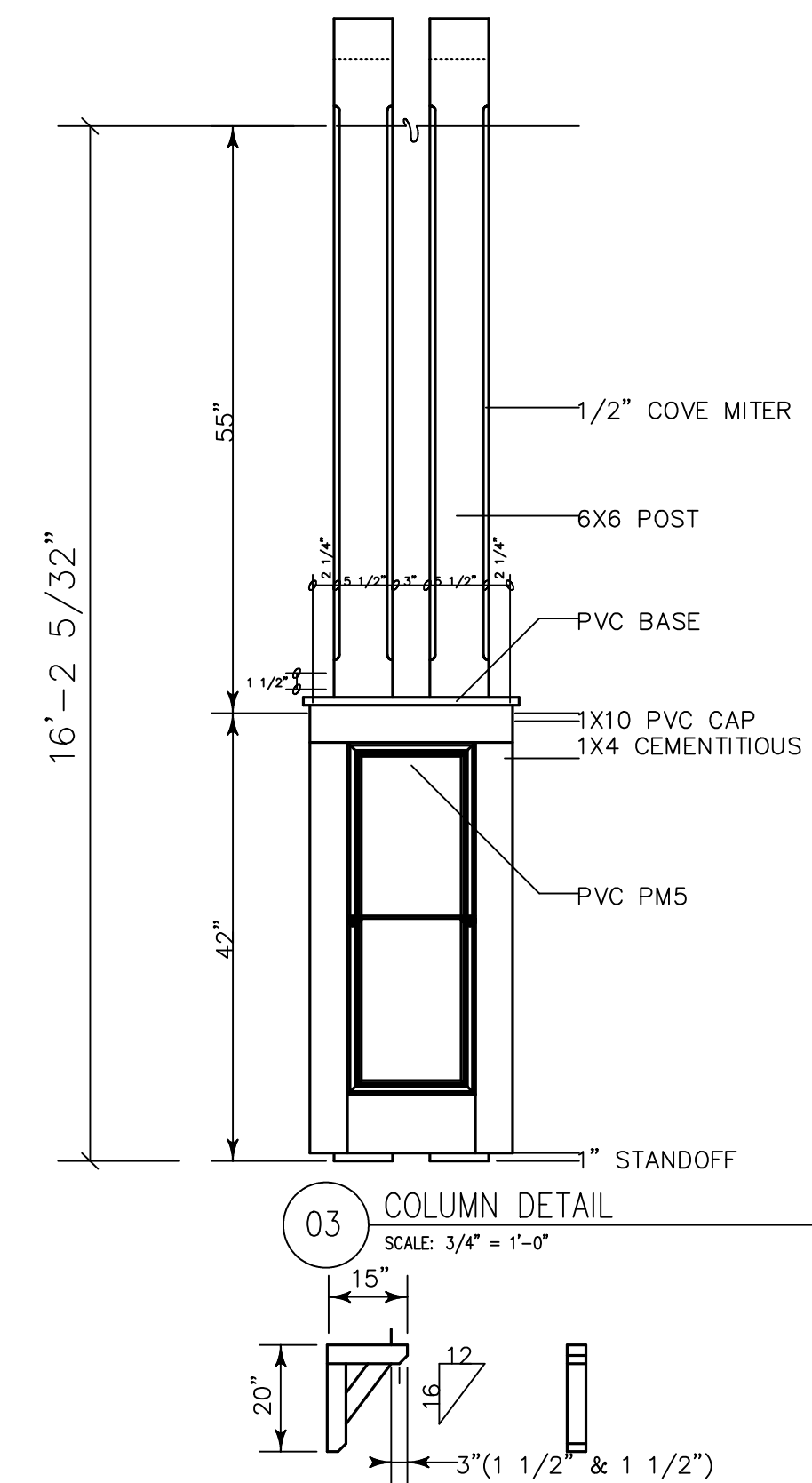
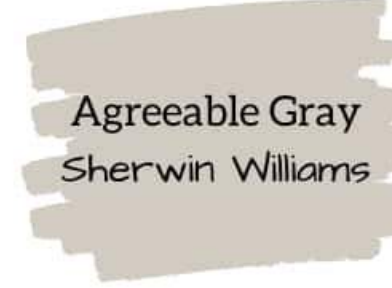
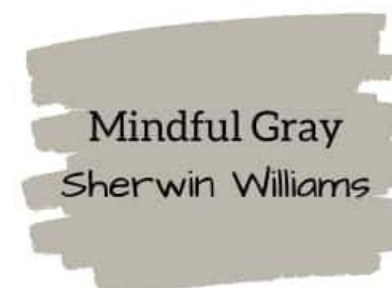

J Rose Architects & Planners 2120 Cosmos Way Argyle, TX 76226 (214) 454-7895 T. jason@jrosearchitect.com



CEMENTITIOUS HARDIE TEXTURES

Front Facade Material Standards within the PD Narrative: Masonry: 100%\* Brick or Stone: Unit Masonry : 40%\* Cementitious Fiber: 60% -Maximum\* \*Exclusive of Doors & Windows

WWW.LIFEONSOUTHPOINTEDRIVE.COM



01 FRONT ELEVATION

SCALE 3/8"=1'-0"

01 FRONT ELEVATION

SCALE 3/8"=1'-0"



- Consultants: Civil Engineer: Oracle Engineering Matt Kostial, P.E. 2204 Green Hill Drive McKinney, TX 75070 (214) 226-5325 Tel. mattkostial@sbcglobal.net Surveyor: Duenes Land Surveying, LLC Dustin Davison, R.P.L.S. 2112 Blackfoot Trail Mesquite, TX 75149 (214) 311-0685 Tel. dustin@dueneslandsurveying.com Geotechnical Engineer: Rone Engineering Mark D. Gray, P.E. 8908 Ambassador Row Dallas, TX 75241 Tel. (214) 630-9145 Tel. mgray@roneengineers.com

Project Title: Quarry Residences

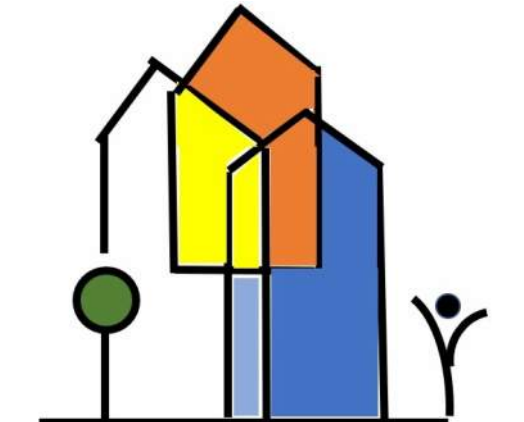

3000 Parkridge Dr. Corinth, TX 76201

Sheet Title: Exhibit F Front Elevation

Drawn by: JRR Date Created: 2-13-2023

SHEET

Exhibit F-2

Revised on: 2-13-2023





ACME BRICK KINGSIZE  
COLOR: "WINTERSTONE"



ACME BRICK KINGSIZE  
COLOR: "WHITE SAGE"



ACME BRICK KINGSIZE  
COLOR: "PINE RIDGE"

THE MOST POPULAR  
Farmhouse Paint Colors  
FOR THAT FIXER UPPER LOOK

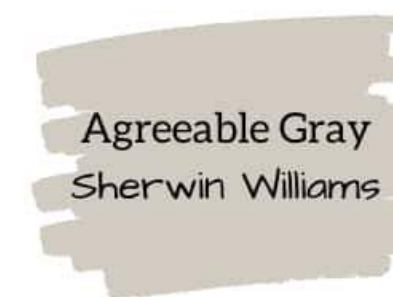
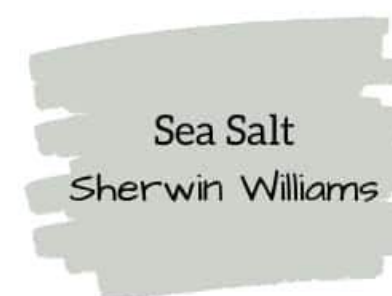
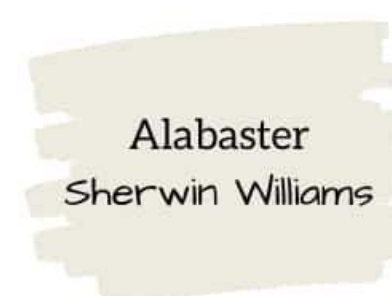
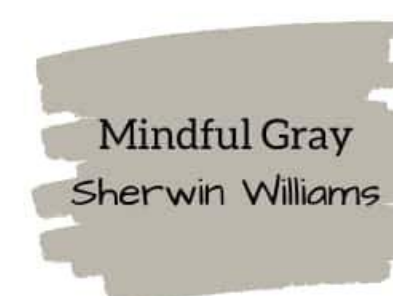

WWW.LIFEONSOUTHPOINTEDRIVE.COM



CEMENTITIOUS HARDIE  
TEXTURES

Front Facade Material Standards within  
the PD Narrative:  
Masonry: 100%\*  
Brick or Stone: Unit Masonry : 40%\*  
Cementitious Fiber: 60% -Maximum\*  
\*Exclusive of Doors & Windows

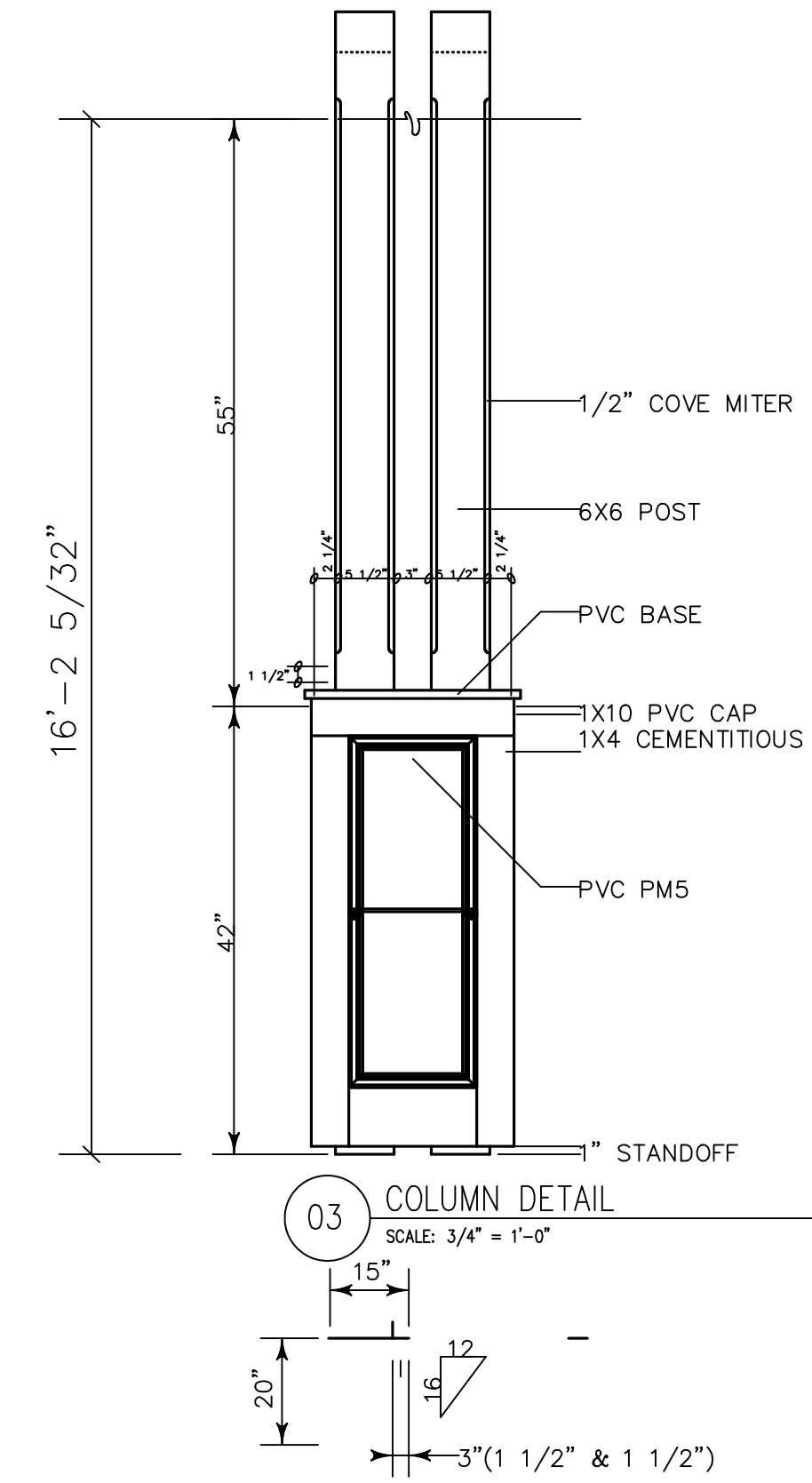

03 COLUMN DETAIL  
SCALE: 3/4" = 1'-0"

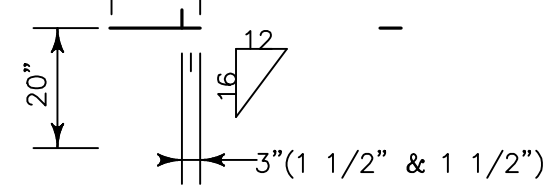

01 BRACKET DETAIL  
SCALE: 3/4" = 1'-0"



**J Rose Architects & Planners**  
2120 Cosmos Way  
Argyle, TX 76226  
(214) 454-1895 T.  
jason@jrosearchitect.com



**Consultants:**

Civil Engineer:  
Oracle Engineering  
Matt Kostial, P.E.  
2204 Green Hill Drive  
McKinney, TX 75070  
(214) 226-5325 Tel.  
mattkostial@sbcglobal.net

Surveyor:  
Duenes Land Surveying, LLC  
Dustin Davison, R.P.L.S.  
2112 Blackfoot Trail  
Mesquite, TX 75149  
(214) 311-0685 Tel.  
dustin@dueneslandsurveying.com

Geotechnical Engineer:  
Rone Engineering  
Mark D. Gray, P.E.  
8908 Ambassador Row  
Dallas, TX 75241 Tel.  
(214) 630-9745 Tel.  
mgray@roneengineers.com

**Project Title:**  
Quarry  
Residences

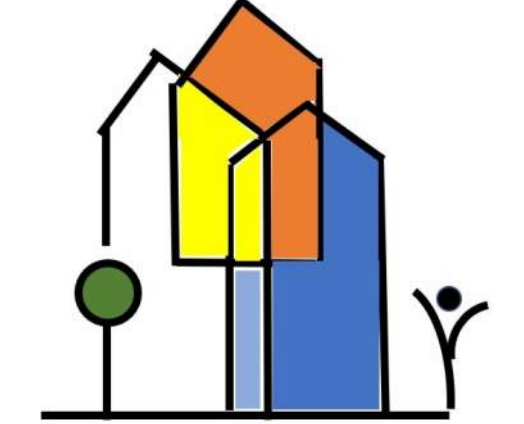

3000 Parkridge Dr.  
Corinth, TX 76201

**Sheet Title:**  
Exhibit F  
Front  
Elevation

Drawn by: JRR  
Date Created: 2-13-2023

SHEET

**Exhibit F-3**

Revised on: 2-13-2023



01 FRONT ELEVATION

SCALE 3/8"=1'-0"



01 FRONT ELEVATION

SCALE 3/8"=1'-0"

Scale: 1"=40'-0"







ACME BRICK KINGSIZE COLOR: "WINTERSTONE"

ACME BRICK KINGSIZE COLOR: "WHITE SAGE"

ACME BRICK KINGSIZE COLOR: "PINE RIDGE"



CEMENTITIOUS HARDIE TEXTURES

Front Facade Material Standards within the PD Narrative: Masonry: 100%\* Brick or Stone: Unit Masonry : 40%\* Cementitious Fiber: 60% -Maximum\* \*Exclusive of Doors & Windows

THE MOST POPULAR Farmhouse Paint Colors FOR THAT FIXER UPPER LOOK

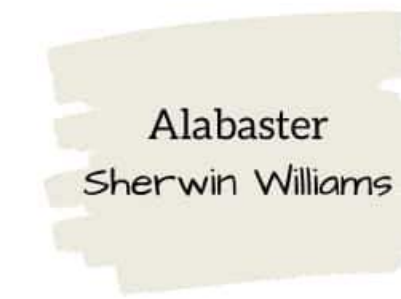

WWW.LIFEONSOUTHPOINTEDRIVE.COM

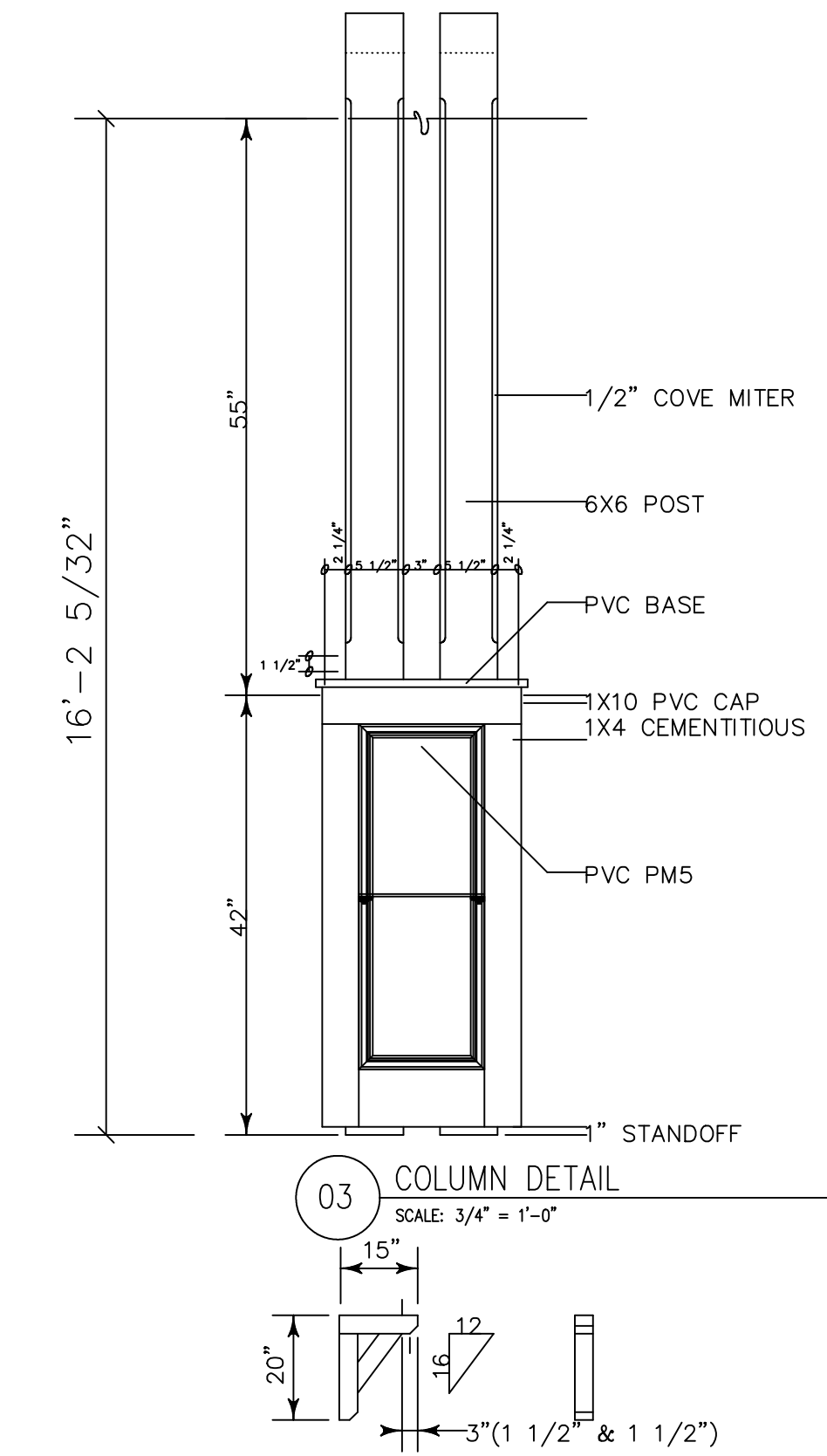

J Rose Architects & Planners 2120 Cosmos Way Argyle, TX 76226 (214) 454-7895 T. jason@jrosearchitect.com



Consultants: Civil Engineer: Oracle Engineering Matt Kostial, P.E. 2204 Green Hill Drive McKinney, TX 75070 (214) 226-5325 Tel. mattkostial@sbcglobal.net Surveyor: Duenes Land Surveying, LLC Dustin Davison, R.P.L.S. 2112 Blackfoot Trail Mesquite, TX 75149 (214) 317-0485 Tel. dustin@dueneslandsurveying.com Geotechnical Engineer: Rone Engineering Mark D. Gray, P.E. 8908 Ambassador Row Dallas, TX 75241 Tel. (214) 630-9145 Tel. mgray@roneengineers.com

Project Title: Quarry Residences

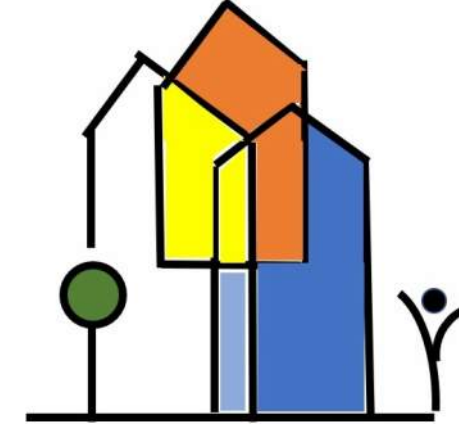

3000 Parkridge Dr. Corinth, TX 76201

Sheet Title: Front Elevation

Drawn by: JRR Date Created: 1-23-2023

SHEET

Exhibit F-4

Revised on: 1-23-2023



01 FRONT ELEVATION (TOWNHOUSE)

SCALE 3/8"=1'-0"

Scale: 1"=40'-0"

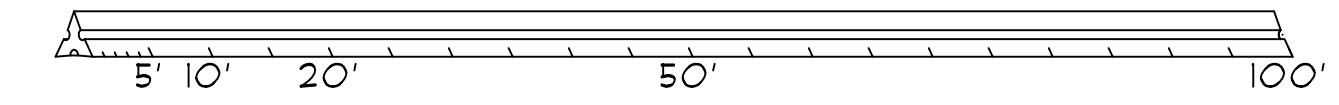



Front Facade Material Standards within the PD Narrative:  
Masonry: 100%\*  
Brick or Stone: Unit Masonry : 0%\*  
Cementitious Fiber: 100% -Maximum\*  
\*Exclusive of Doors & Windows



**J Rose Architects & Planners**  
2120 Cosmos Way  
Argyle, TX 76226  
(214) 454-7895 T.  
jason@jrosearchitect.com



**01 LEFT ELEVATION (FACING STREETS & INTERNAL DRIVES)**  
SCALE 3/8"=1'-0"

**Consultants:**

2004 Civil Engineer EL 8'-1 1/8"  
Oracle Engineering  
Matt Kostial, P.E.  
2204 Green Hill Drive  
McKinney, TX 75070  
(214) 226-5325 Tel.  
mattkostial@sbcglobal.net

Surveyor:  
Duenes Land Surveying, LLC  
Dustin Davison, R.P.L.S.  
2112 Blackfoot Trail  
Mesquite, TX 75149  
(214) 317-0685 Tel.  
dustin@dueslandsurveying.com

Geotechnical Engineer:  
Rone Engineering  
Mark D. Gray, P.E.  
8908 Ambassador Row  
Dallas, TX 75241 Tel.  
(214) 630-9745 Tel.  
mgray@roneengineers.com

**Project Title:**

**Quarry Residences**

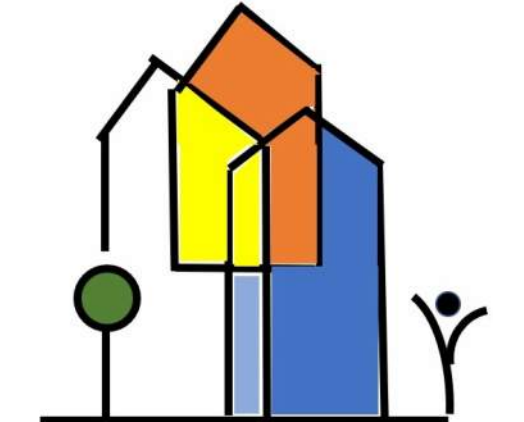

3000 Parkridge Dr.  
Corinth, TX 76201

**Sheet Title:**  
**Left Side Elevation**

Drawn by: JRR  
Date Created: 1-23-2023

SHEET

**Exhibit F-5**

Revised on: 1-23-2023



Front Facade Material Standards within the PD Narrative:  
Masonry: 100%\*  
Brick or Stone: Unit Masonry : 0%\*  
Cementitious Fiber: 100% –Maximum\*  
\*Exclusive of Doors & Windows



**J Rose Architects & Planners**  
2120 Cosmos Way  
Argyle, TX 76226  
(214) 454-7895 T.  
jason@jrosearchitect.com



**Consultants:**

Civil Engineer:  
Oracle Engineering  
Matt Kostial, P.E.  
2204 Green Hill Drive  
McKinney, TX 75070  
(214) 226-5325 Tel.  
mattkostial@sbcglobal.net

Surveyor:  
Duenes Land Surveying, LLC  
Dustin Davison, R.F.L.S.  
2112 Blackfoot Trail  
Mesquite, TX 75149  
(214) 211-0685 Tel.  
dustin@dueneslandsurveying.com

Geotechnical Engineer:  
Rone Engineering  
Mark D. Gray, P.E.  
8908 Ambassador Row  
Dallas, TX 75241 Tel.  
(214) 630-9745 Tel.  
mgray@roneengineers.com

Project Title:  
**Quarry Residences**

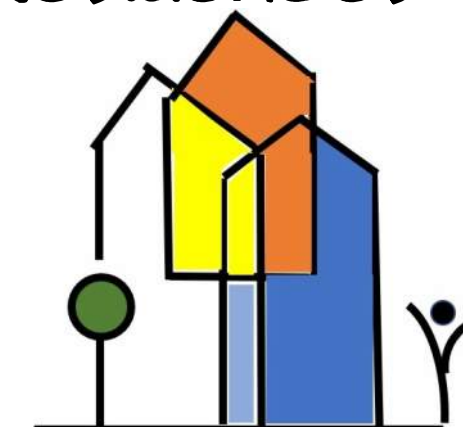

3000 Parkridge Dr.  
Corinth, TX 76201

Sheet Title:  
**Right Side Elevation**

Drawn by: JRR  
Date Created: 9-19-2022

SHEET

**Exhibit F-6**

Revised on: 9-19-2022



**01 RIGHT ELEVATION**

SCALE 3/8"=1'-0"

Scale: 1"=40'-0"

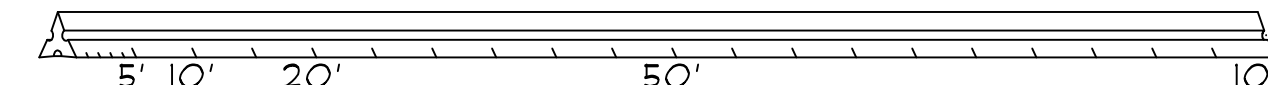

Front Facade Material Standards within the PD Narrative:

Masonry: 100%\*

Brick or Stone: Unit Masonry : 0%\*

Cementitious Fiber: 100% –Maximum\*

\*Exclusive of Doors & Windows



**J Rose Architects & Planners**

2120 Cosmos Way  
Argyle, TX 76226  
(214) 454-7895 T.  
jason@jrosearchitect.com



1-23-2023

**Consultants:**

Civil Engineer:  
Oracle Engineering  
Matt Kostial, P.E.  
2204 Green Hill Drive  
McKinney, TX 75070  
(214) 226-5325 Tel.  
mattkostial@sbcglobal.net

Surveyor:  
Duenes Land Surveying, LLC  
Dustin Davison, R.P.L.S.  
2112 Blackfoot Trail  
Mesquite, TX 75149  
(214) 317-0685 Tel.  
dustin@dueneslandsurveying.com

Geotechnical Engineer:  
Rone Engineering  
Mark D. Gray, P.E.  
8908 Ambassador Row  
Dallas, TX 75247 Tel.  
(214) 630-9745 Tel.  
mgray@roneengineers.com

**Project Title:**

**Quarry Residences**

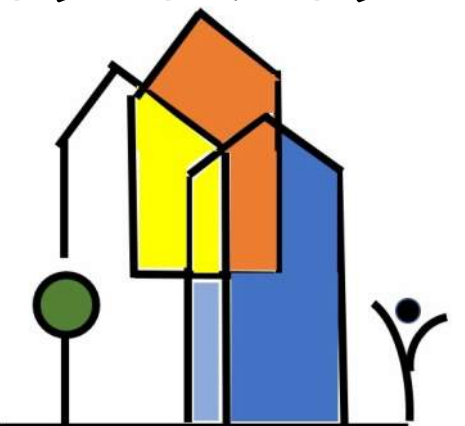

3000 Parkridge Dr.  
Corinth, TX 76201

**Sheet Title:**

**Back Elevation**

Drawn by: JRR  
Date Created: 1-23-2023

SHEET

**Exhibit F-7**

Revised on: 1-23-2023



**01 REAR ELEVATION**

SCALE 3/8"=1'-0"

Scale: 1"=40'-0"







**J Rose Architects & Planners**  
 2120 Cosmos Way  
 Argyle, TX 76226  
 (214) 454-7895 T.  
 jason@jrosearchitect.com



8-15-2021

**Consultants:**

**Civil Engineer:**  
 Oracle Engineering  
 Matt Kostial, P.E.  
 2204 Green Hill Drive  
 McKinney, TX 75070  
 (214) 226-5325 Tel.  
 mattkostial@sbcglobal.net

**Surveyor:**  
 Duenes Land Surveying, LLC  
 Dustin Davison, R.P.L.S.  
 2112 Blackfoot Trail  
 Mesquite, TX 75149  
 (214) 317-0485 Tel.  
 dustin@dueneslandsurveying.com

**Geotechnical Engineer:**  
 Rone Engineering  
 Mark D. Gray, P.E.  
 8908 Ambassador Row  
 Dallas, TX 75241 Tel.  
 (214) 630-9745 Tel.  
 mgray@roneengineers.com

**Project Title:**  
**Quarry Residences**

3000 Parkridge Dr.  
 Corinth, TX 76201

**Sheet Title:**  
**Front Column Detail**

Drawn by: JRR  
 Date Created: 8-15-2021

SHEET

**Exhibit F-8**

Revised on: 7-21-2021

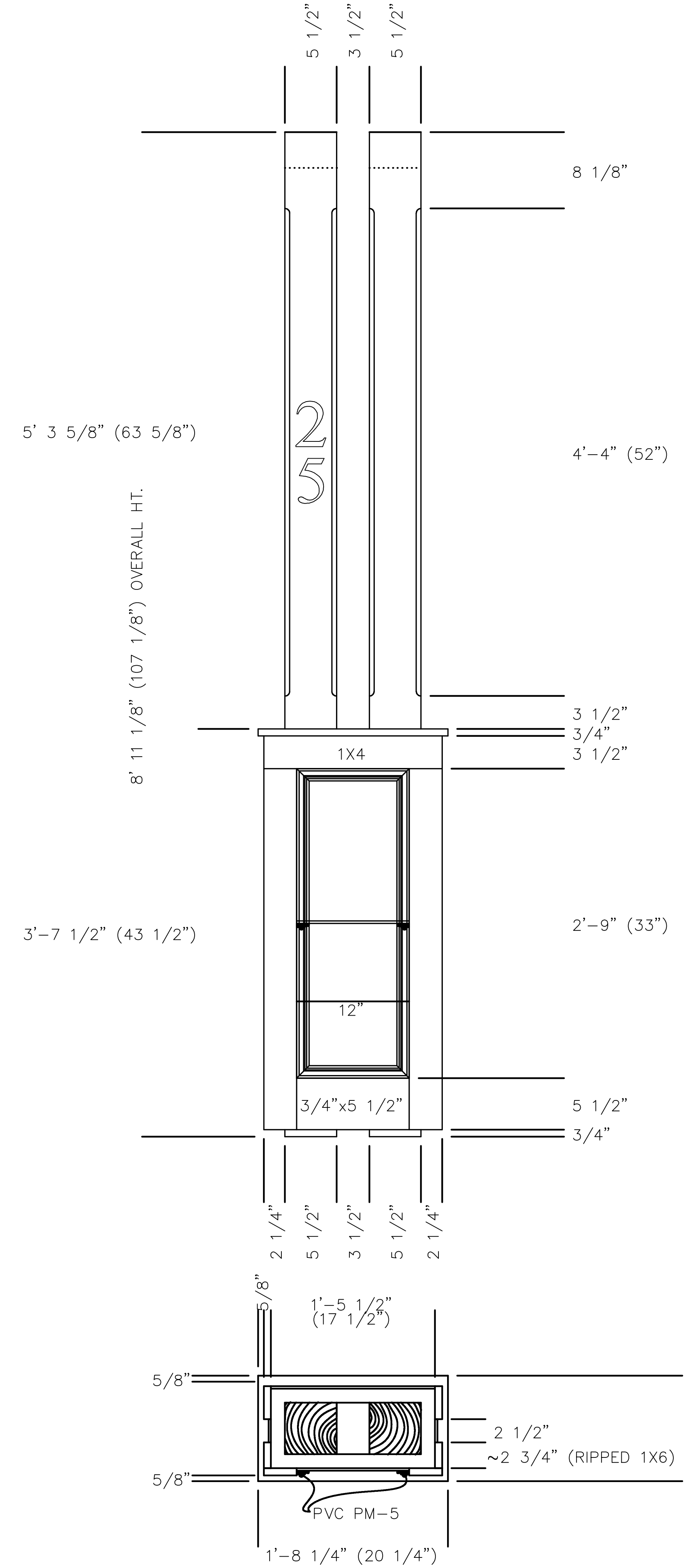

- HardieSoffit<sup>®</sup> Panels 144" L. 12" Width
- HardieSoffit<sup>®</sup> Panels 144" L. 16" Width
- HardieTrim<sup>®</sup> Board 144" L. 3.5" Width
- HardieTrim<sup>®</sup> Board 144" L. 5.5" Width
- HardieTrim<sup>®</sup> Board 144" L. 9.25" Width

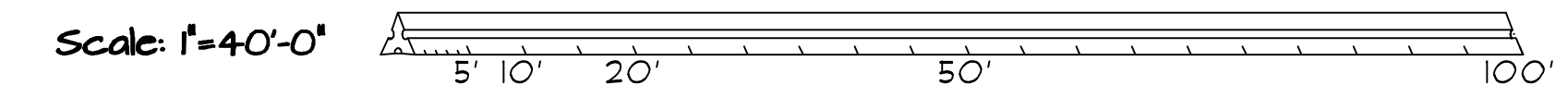
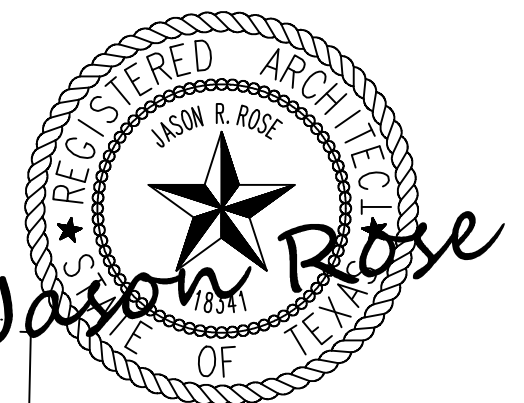

**EXHIBIT "G"**  
**OPEN SPACE EXHIBIT**





**J Rose Architects & Planners**  
 2120 Cosmos Way  
 Argyle, TX 76226  
 (214) 454-7895 T.  
 jason@jrosearchitect.com



2-13-2023

**Consultants:**

**Civil Engineer:**  
 Oracle Engineering  
 Matt Kostial, P.E.  
 2204 Green Hill Drive  
 McKinney, TX 75070  
 (214) 226-5325 Tel.  
 mattkostial@sbcglobal.net

**Surveyor:**  
 Duenes Land Surveying, LLC  
 Dustin Davison, R.P.L.S.  
 2112 Blackfoot Trail  
 Mesquite, TX 75149  
 (214) 317-0685 Tel.  
 dustin@dueneslandsurveying.com

**Geotechnical Engineer:**  
 Rone Engineering  
 Mark D. Gray, P.E.  
 8908 Ambassador Row  
 Dallas, TX 75247 Tel.  
 (214) 630-9745 Tel.  
 mgray@roneengineers.com

**Project Title:**  
**Quarry**

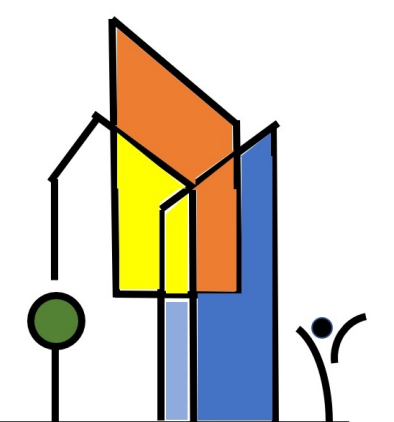

3000 Parkridge Dr.  
 Corinth, TX 76201

**Sheet Title:**  
**Shaded Open Space Exhibit**

Drawn by: JRR  
 Date Created: 2-13-2023

**Exhibit G**

SHEET  
**K**

Revised on: 2-13-2023



MUTUAL DRAINAGE EASEMENT

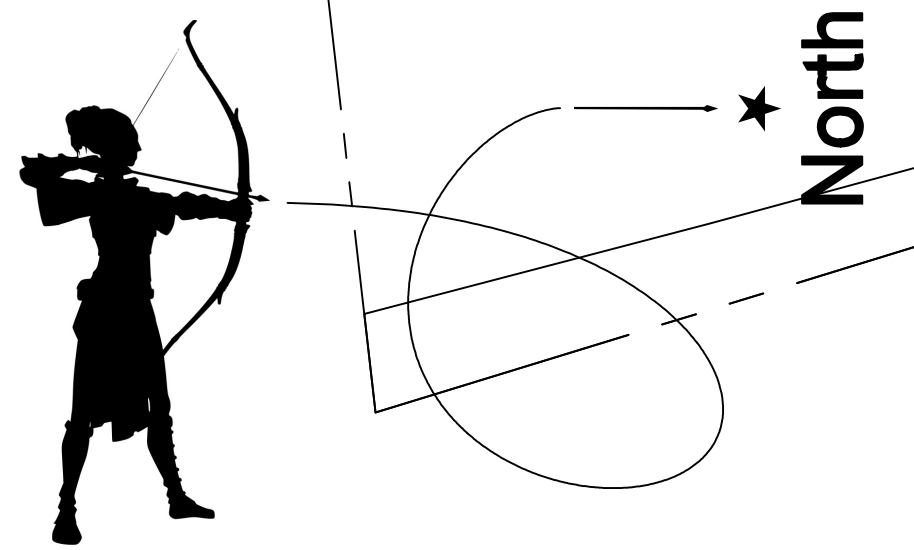

01 SHADED OPEN SPACE EXHIBIT  
 SCALE 1"=40'-0"

**Legend:**

- Lake Recreation Lot (Lot 1X)
- Amenitized North Detention Pond (Lot 4X)
- South Open Space Lot (Lot 2X)
- Dog Park (Lot 3X)
- Activity Nodes (1,444 SF x4)
- Parkridge Trail (8'x685.51')
- Quarry Trail (8'x395.29')
- Fenced Private Yards (90 EA X 350 SF)
- Misc. Open Space Area (Exclusive of Paving)\*

\*does not count towards any recreation or open space requirements.

**Area:**

- 117,175 sf / 2.690 ac
- 21,285 sf / .489 ac
- 22,902 sf / 0.526 ac
- 4,417 sf / .101 ac
- 5,776 sf / .133 ac
- 5,484 sf / .126 ac
- 3,162sf / .073 ac
- 31,500 sf / .723 ac
- 30,648 sf / 0.704 ac





<b>OFFICIAL USE:</b>
<b>Case Number:</b> PDA24-0009
<b>Fees Paid:</b>

**Site Address (Attach Location Map):** 3000 Parkridge Drive, Corinth, TX 76226 (Location Map Attached)

**Approved PD:** ZAPD21-0002

**Name (Applicant/Authorized Agent):** Jason Rose

**Applicant Signature:** \_\_\_\_\_

### Minor PD, Planned Development Amendment Application\*

In accordance with UDC Section 2.10.09.D.1., the Director of Development Services may administratively approve or defer to City Council a Minor PD Amendment and Adjustment to the Planned Development Ordinance.

-----  
 \* Please also complete and attach a [Universal Planning Application](#).

**APPLICANT MODIFICATION/AMENDMENT REQUEST - PD to be Amended:** PD-66 Quarry

-----  
**Request:**

To amend PD-66 to reflect the following modifications listed below:

1. Section 2.D.1 of the Planned Development Ordinance shall be amended to clarify that the setbacks listed in Table A of the Planned Development Ordinance shall be measured from the perimeter of the subdivision – with the exception of setbacks measured from lot lines adjacent to Quarry Drive – as depicted in Exhibit D - Planned Development Concept Plan and the proposed Site Plan and Preliminary Plat. This is to allow the site to be developed as designed.

This amendment does not exempt the Site Plan, Preliminary Plat, and Final Plat from meeting any requirement of Section 2.D.1 of the Planned Development Ordinance.

2. Section 2.E.2.a shall be amended to add a provision to permit the minimal encroachment of private yards into the landscape buffer along Quarry Drive. Section 2.E.2.a shall read as follows:
  - a. In addition to meeting the landscape regulations found in UDC Section 2.09.01, each unit shall be provided with Private, Fenced Yards. Each individual private fenced yard shall be a minimum of 175 square feet in area. The Private, Fenced Yards of units siding onto Quarry Drive may extend a maximum distance of five (5) feet from the building into the required fifteen (15) foot landscape edge buffer, as depicted in the proposed Site Plan.
3. Section 2.E.14 shall be amended to reflect that the proposed Quarry Drive shall no longer be considered a Collector Street (based on the recommendation of the consulting City Engineer upon review of the Master Thoroughfare Plan) and to amend the previous reduction from 120 feet to 89 feet. Therefore, Section 2.E.14.a shall read as follows:
  - a. UDC 3.05.04.G 1. Driveway Dimensions and Spacing (City Maintained Roadways), Table 25: Dimensions for Driveways at City Maintained Roadways. Criteria: Minimum Centerline Driveway Spacing Along Roadway, Local: 100 Feet, shall be modified to a minimum of 89 feet – as reviewed by the City’s Consulting Engineer based on the proposed Site Plan – to accommodate the design of the eastern most driveway

locations along Quarry Drive, thereby alleviating the requirement of an accessible gate requirement at those driveway entries. Additional minor reductions may be administratively approved by the City Engineer.

**Staff Comments/Conditions:**

-----

Approved/Denied:



\_\_\_\_\_  
Melissa Dailey, AICP

Director of Development Services

Date: 9-3-2024



Quarry Development Site

